

Hierarchical Neural Coding for Controllable CAD Model Generation

ICML 2023

Xiang Xu^{1,2} Pradeep Kumar Jayaraman² Joseph G. Lambourne²
Karl D.D. Willis² Yasutaka Furukawa¹

The logo for Simon Fraser University (SFU), consisting of the letters "SFU" in white on a red rectangular background.

¹Simon Fraser University

The Autodesk logo, featuring a stylized "A" icon followed by the word "AUTODESK" in a bold, sans-serif font.

²Autodesk Research



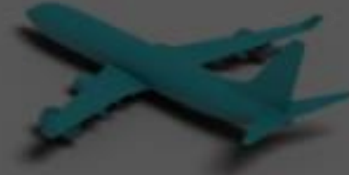

Design intent defines the relationships between different parts of a CAD model



Current Approaches for Controllable CAD Generation

Parametric CAD

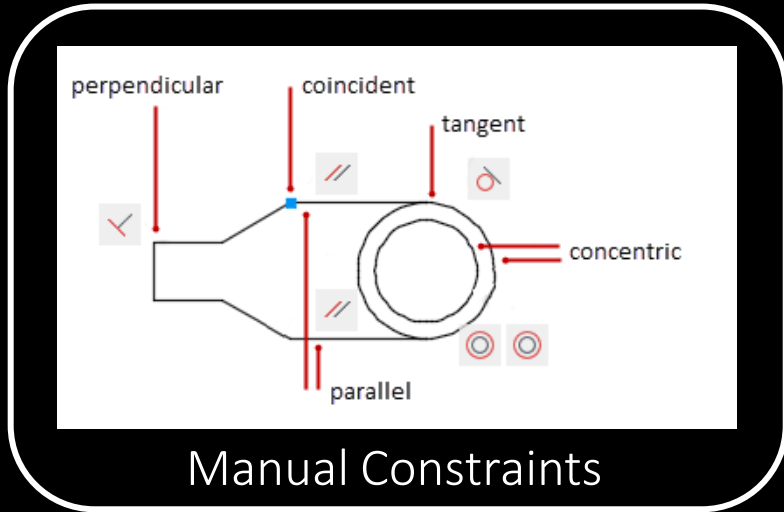

SkexGen

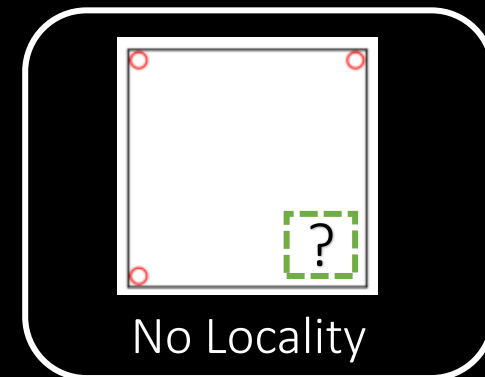
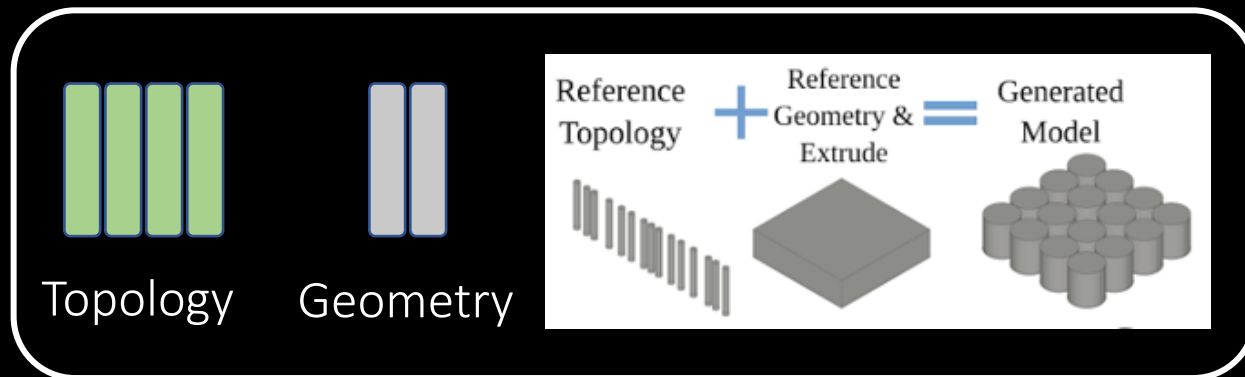

Sketch and Extrude Representation

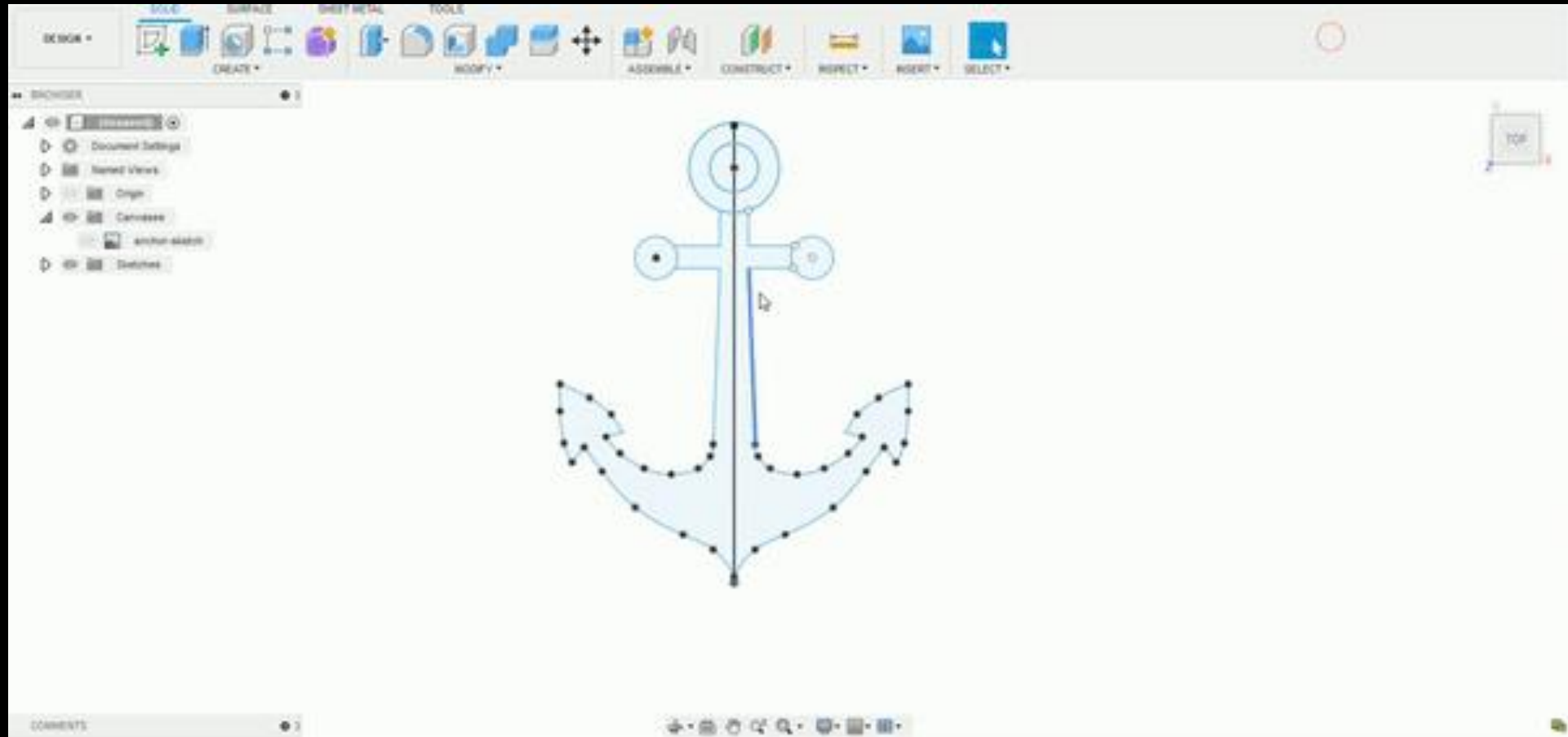

Hierarchical Representation

Solid

Profile

Loop

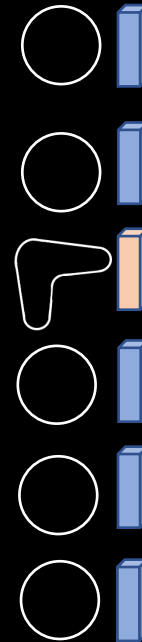

Hierarchical Representation

Solid

Profile

Loop

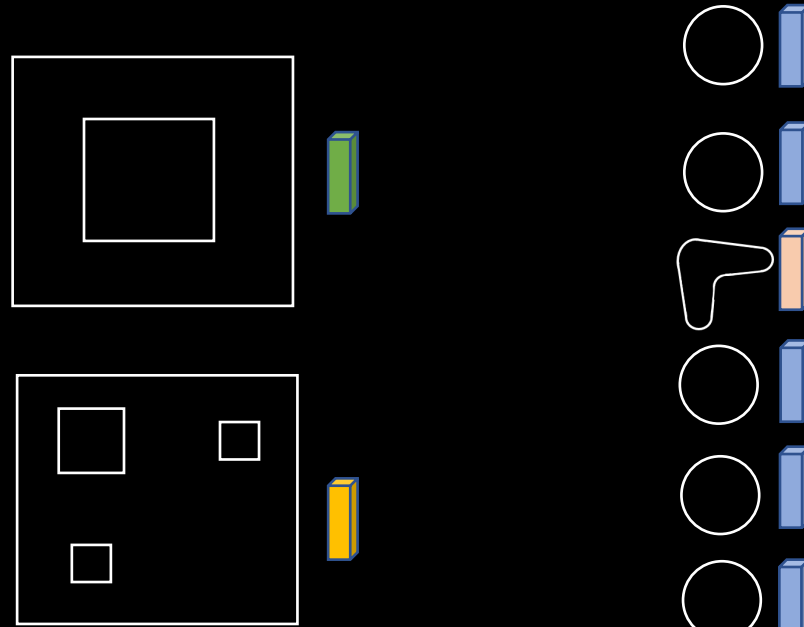

Hierarchical Representation

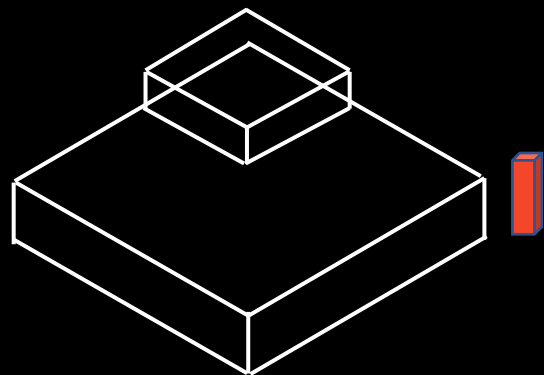

Solid

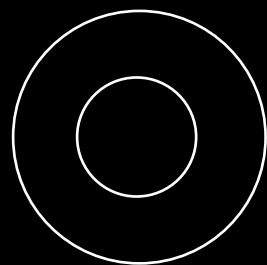

Profile

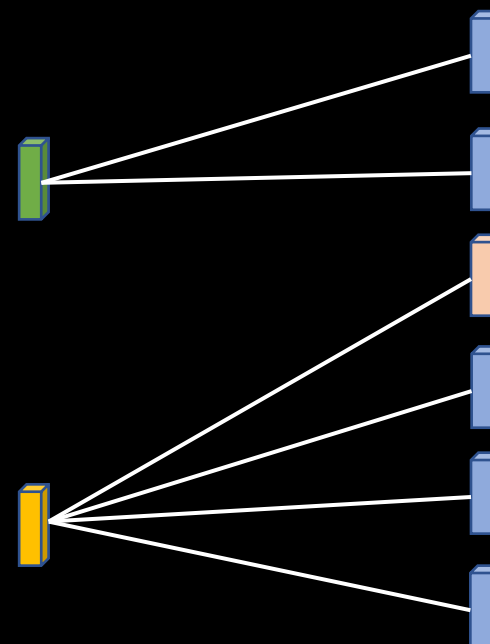
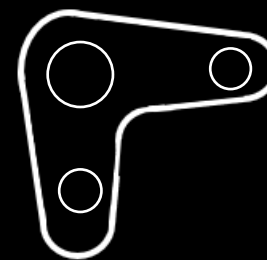

Loop

Hierarchical Representation

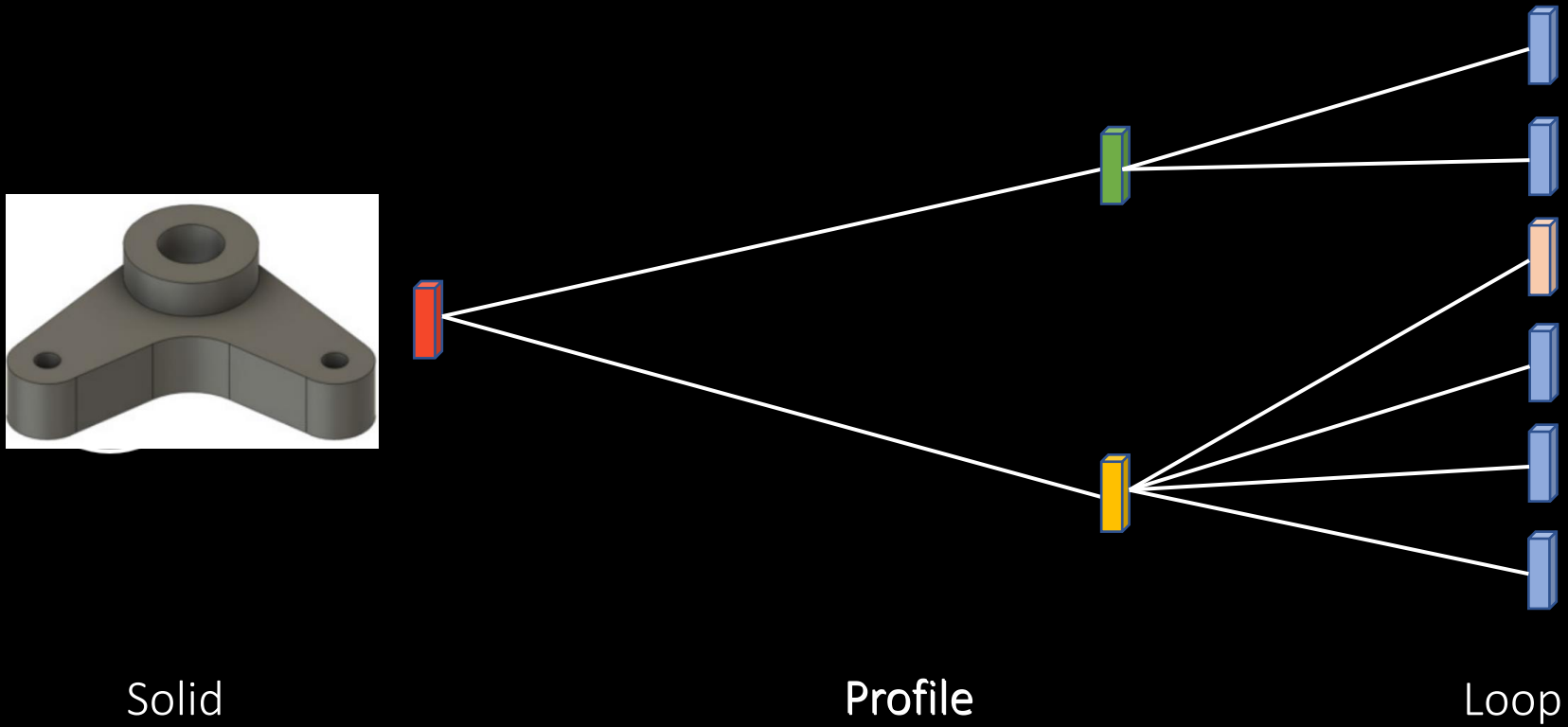

Three-level code tree

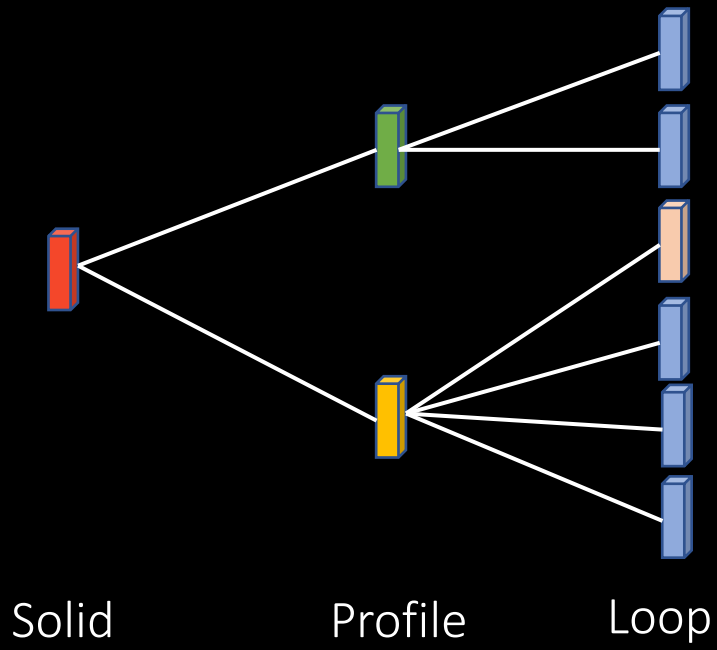

Solid

Profile

Loop

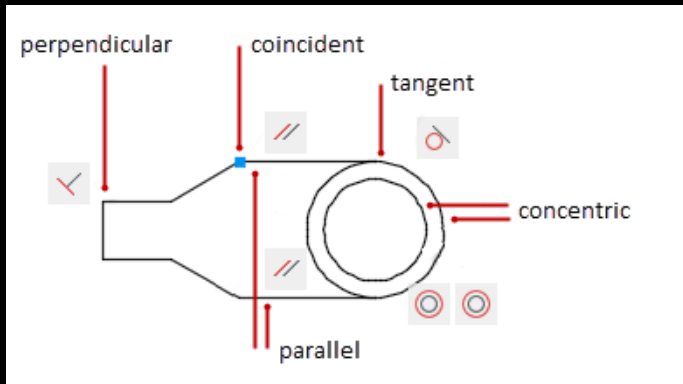

Manual Constraints

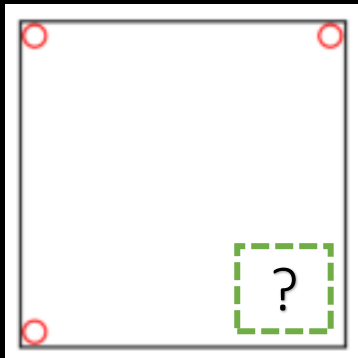

No Locality



Failures After Edit

Three-level code tree

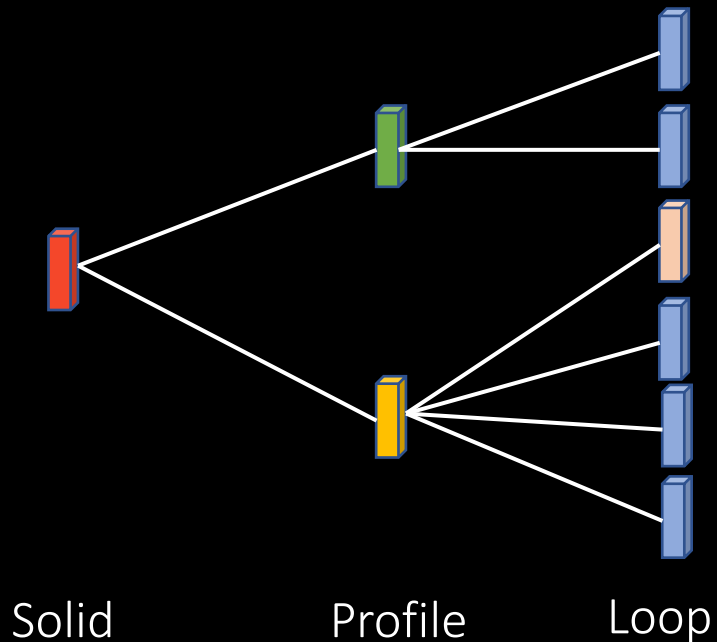

Solid

Profile

Loop

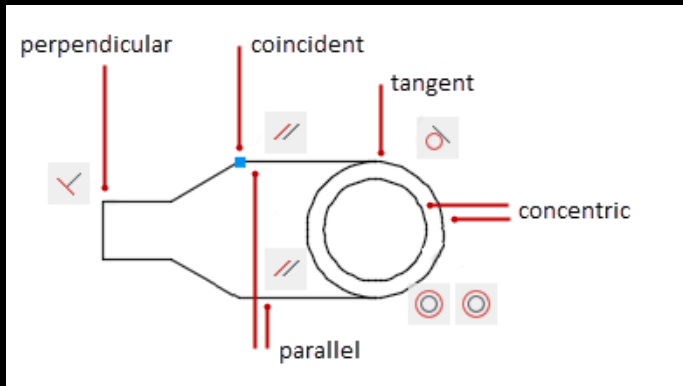

Manual Constraints

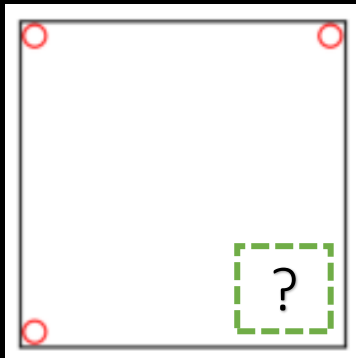

No Locality



Failures After Edit

Three-level code tree

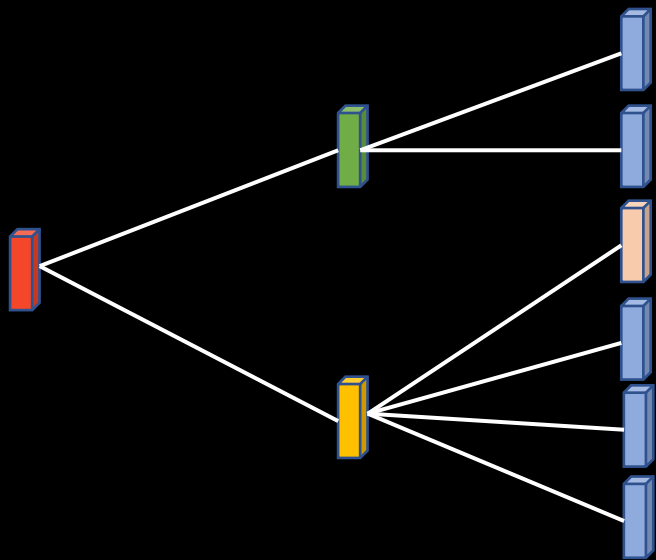

Solid

Profile

Loop

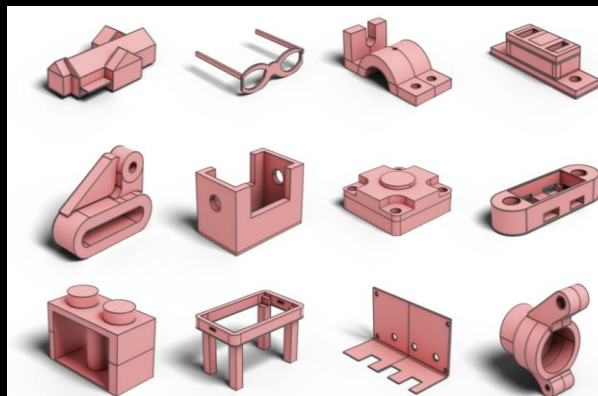

RANDOM GENERATION

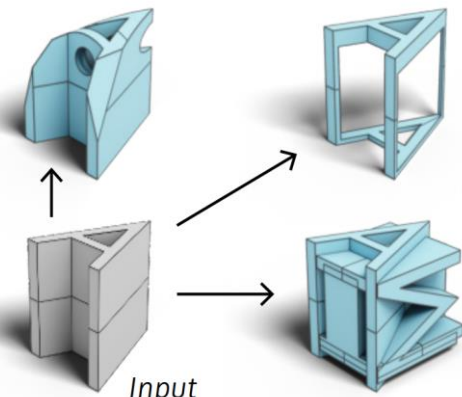
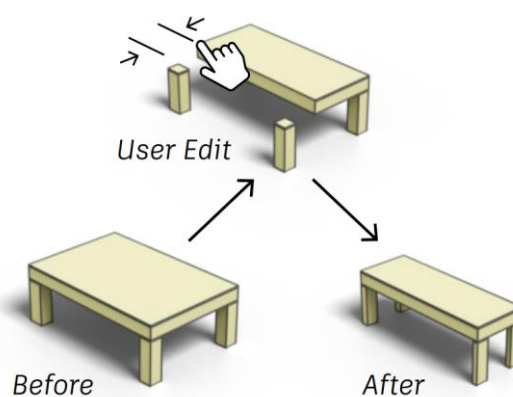

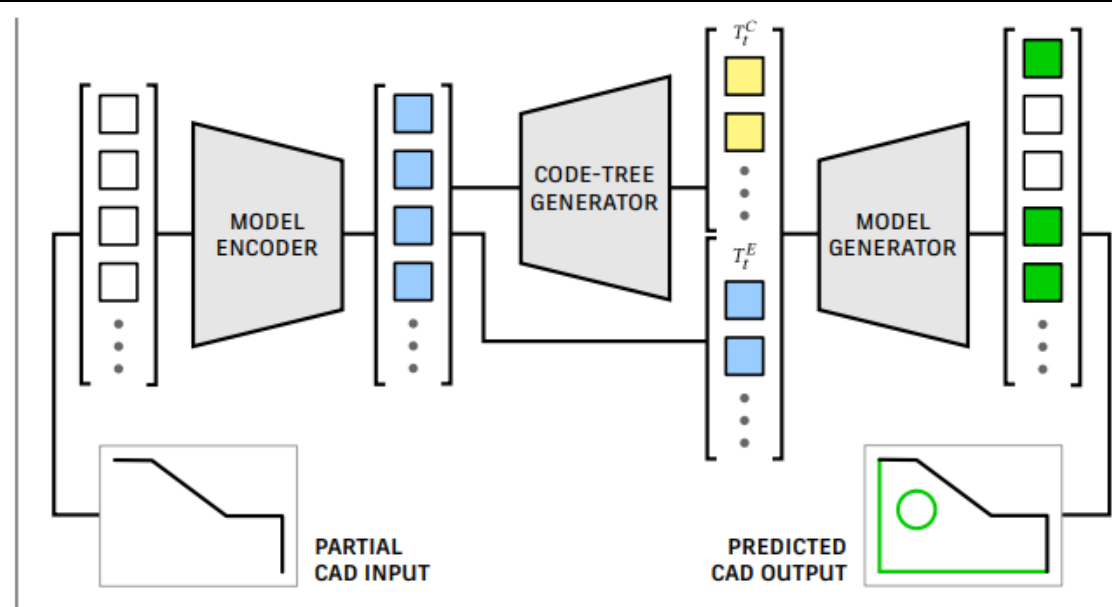
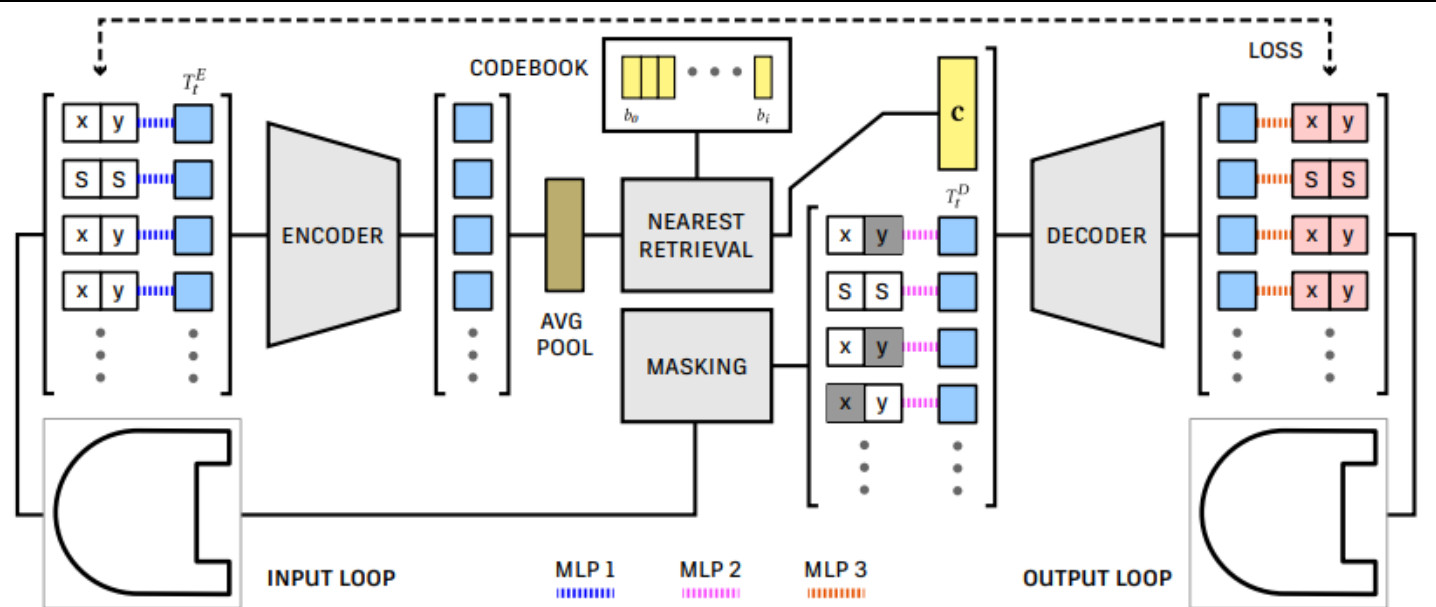

Three-Level Codebook Learning

- Encoder
- Masked skip connection
- Decoder

Controllable CAD Generation

- Model Encoder
- Code-Tree Generator
- Model Generator

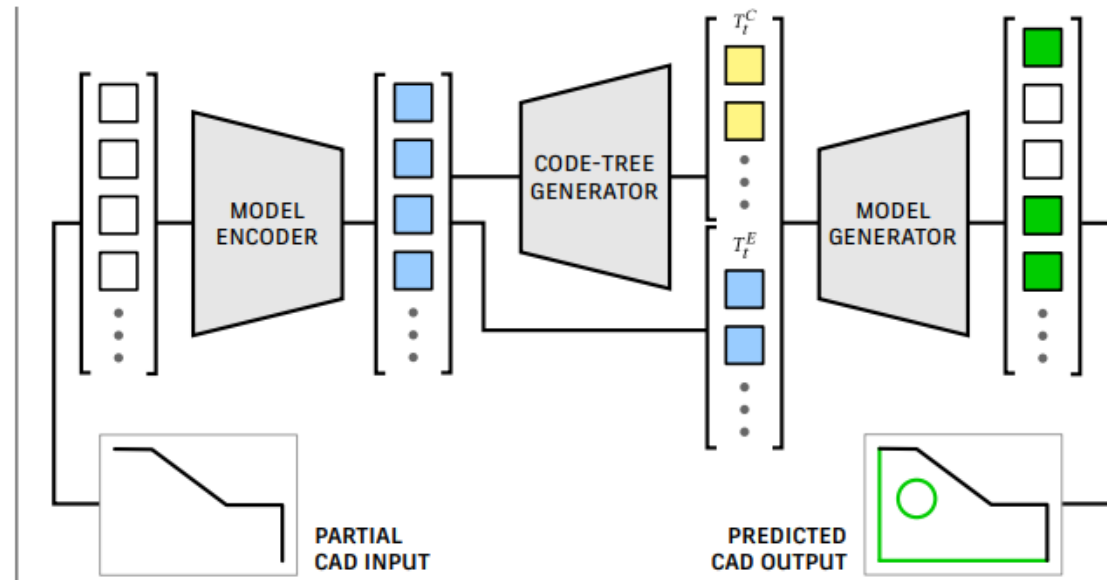
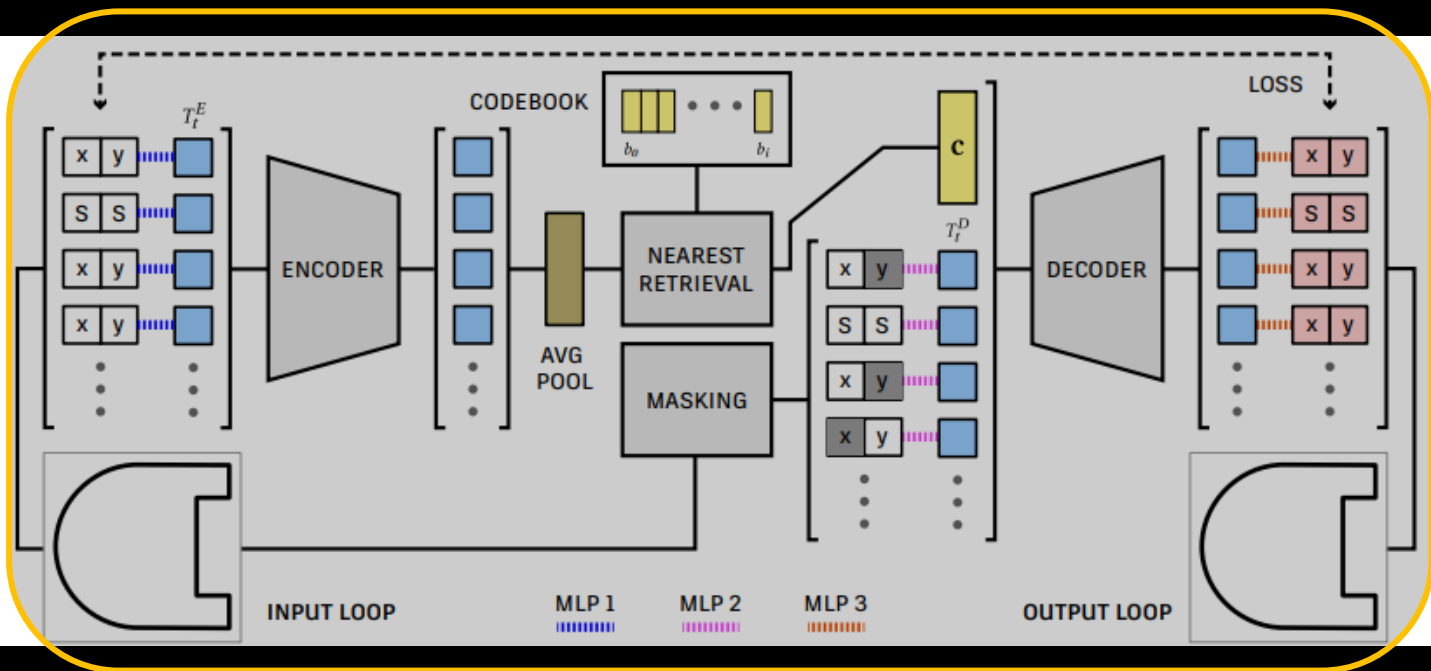

Three-Level Codebook Learning

- Encoder
- Masked skip connection
- Decoder

Controllable CAD Generation

- Model Encoder
- Code-Tree Generator
- Model Generator

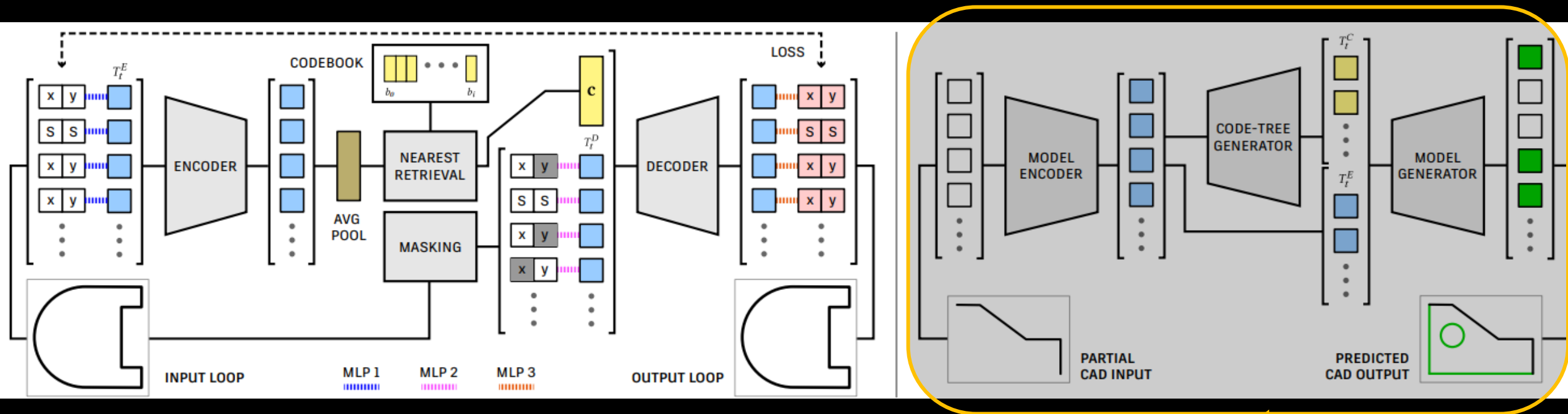

Three-Level Codebook Learning

- Encoder
- Masked skip connection
- Decoder

Controllable CAD Generation

- Model Encoder
- Code-Tree Generator
- Model Generator

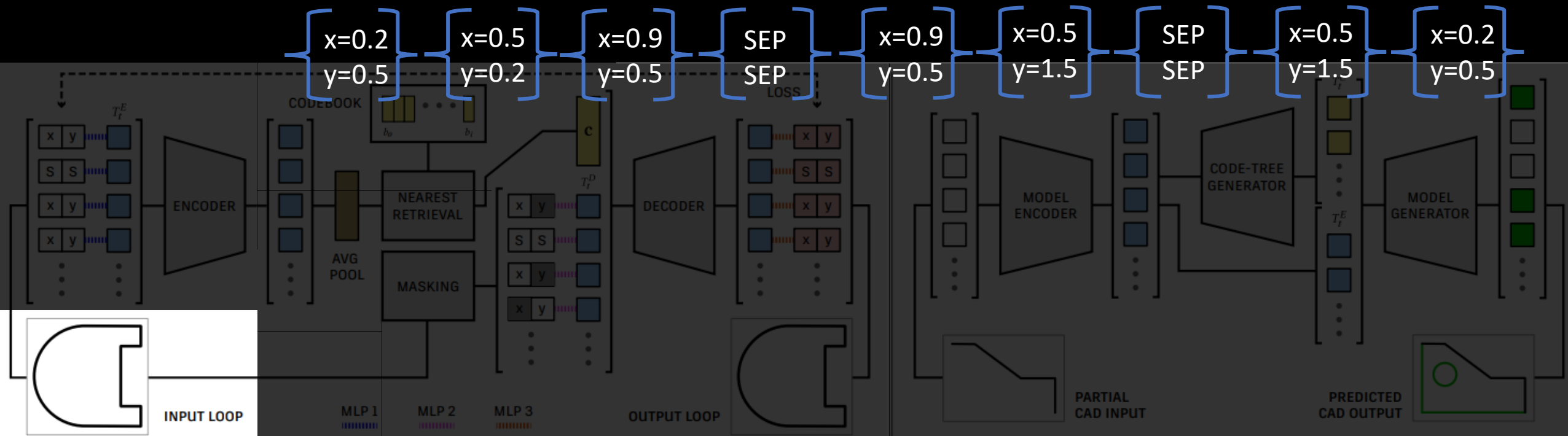

Three-Level Codebook Learning

- Encoder
- Masked skip connection
- Decoder

Controllable CAD Generation

- Model Encoder
- Code-Tree Generator
- Model Generator

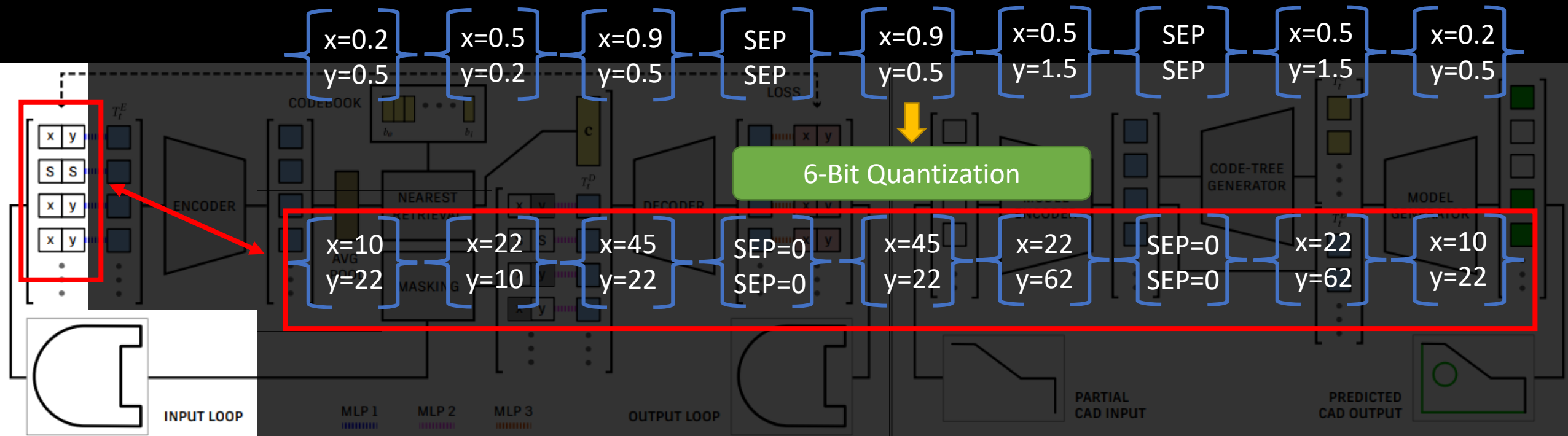

Three-Level Codebook Learning

- Encoder
- Masked skip connection
- Decoder

Controllable CAD Generation

- Model Encoder
- Code-Tree Generator
- Model Generator

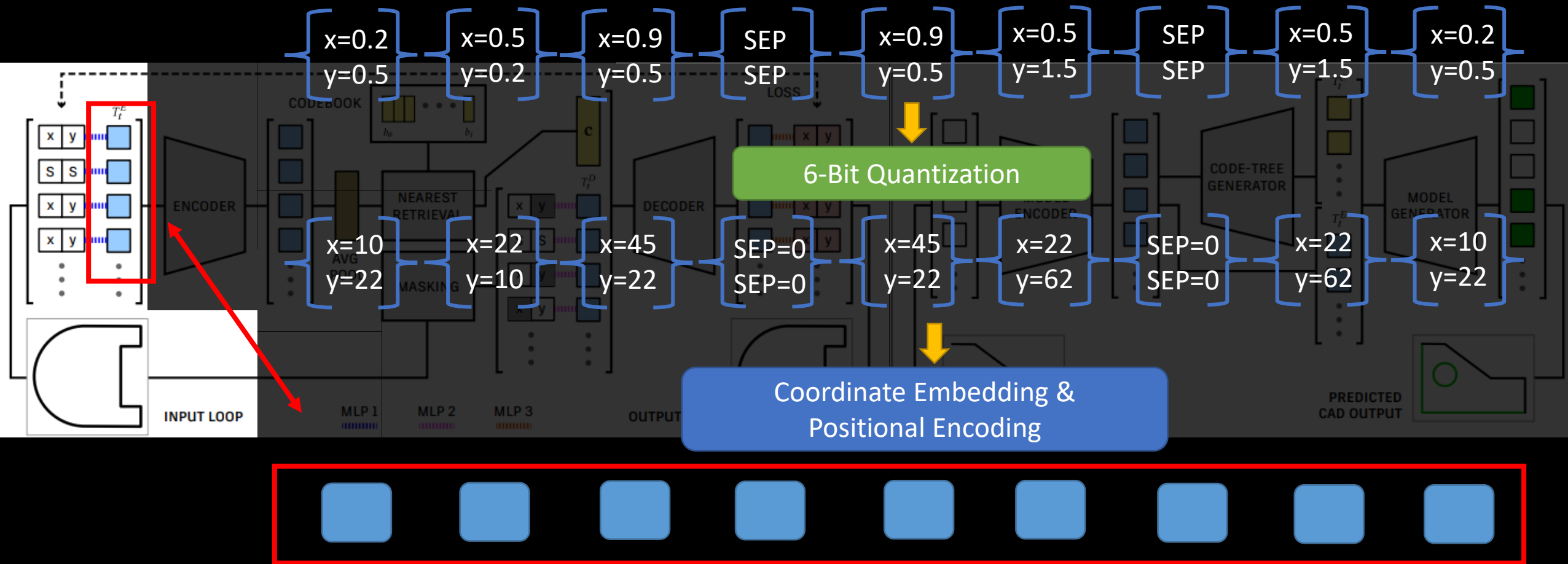

Three-Level Codebook Learning

- Encoder
- Masked skip connection
- Decoder

Controllable CAD Generation

- Model Encoder
- Code-Tree Generator
- Model Generator

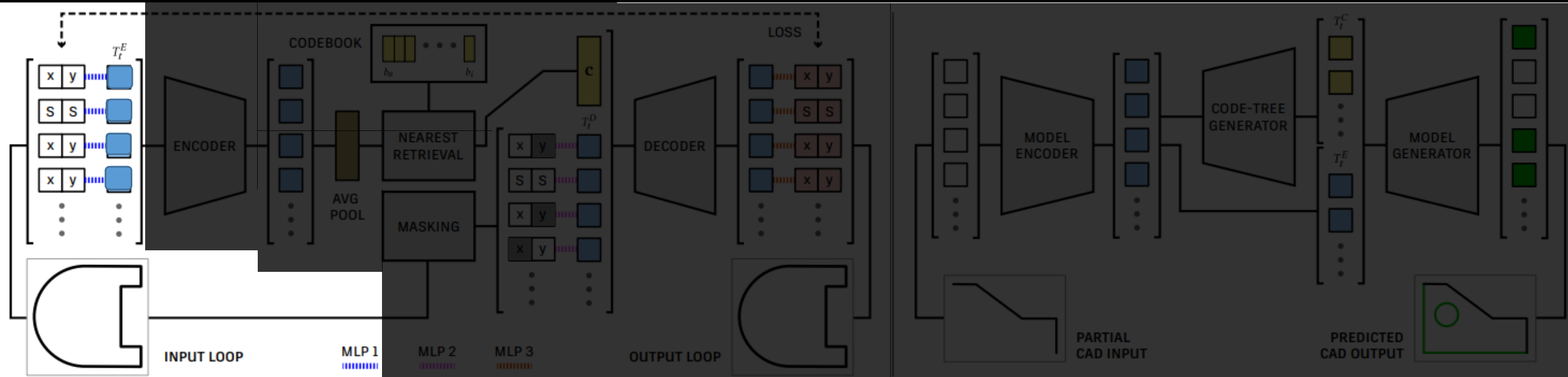

Three-Level Codebook Learning

- Encoder
- Masked skip connection
- Decoder

Controllable CAD Generation

- Model Encoder
- Code-Tree Generator
- Model Generator

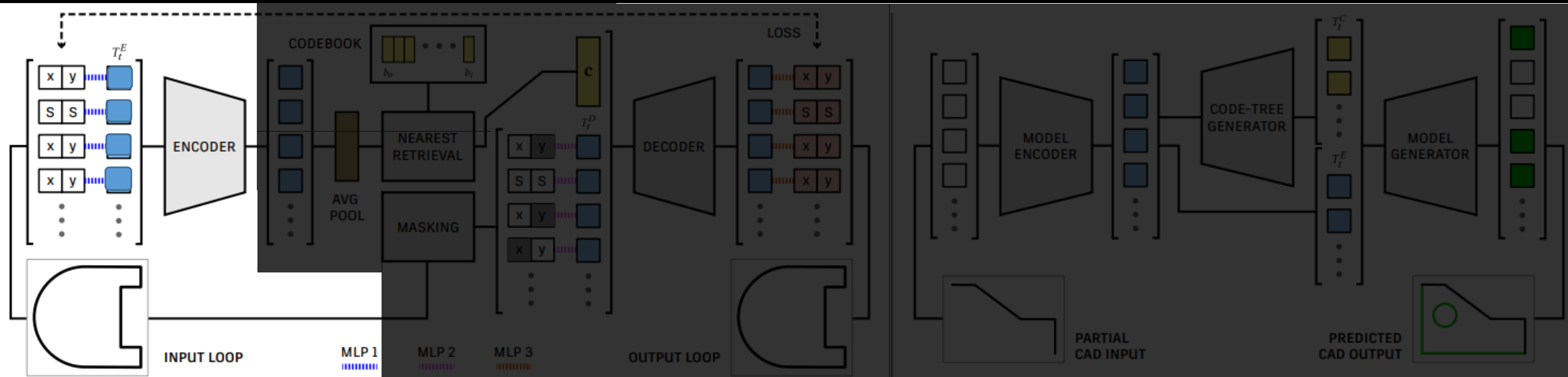

Three-Level Codebook Learning

- Encoder
- Masked skip connection
- Decoder

Controllable CAD Generation

- Model Encoder
- Code-Tree Generator
- Model Generator

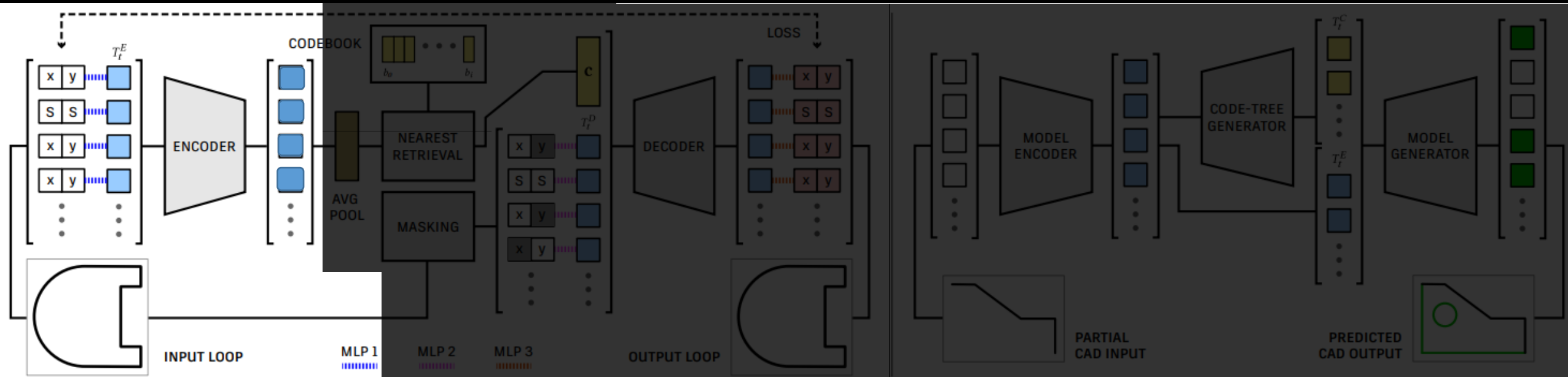

Three-Level Codebook Learning

- Encoder
- Masked skip connection
- Decoder

Controllable CAD Generation

- Model Encoder
- Code-Tree Generator
- Model Generator

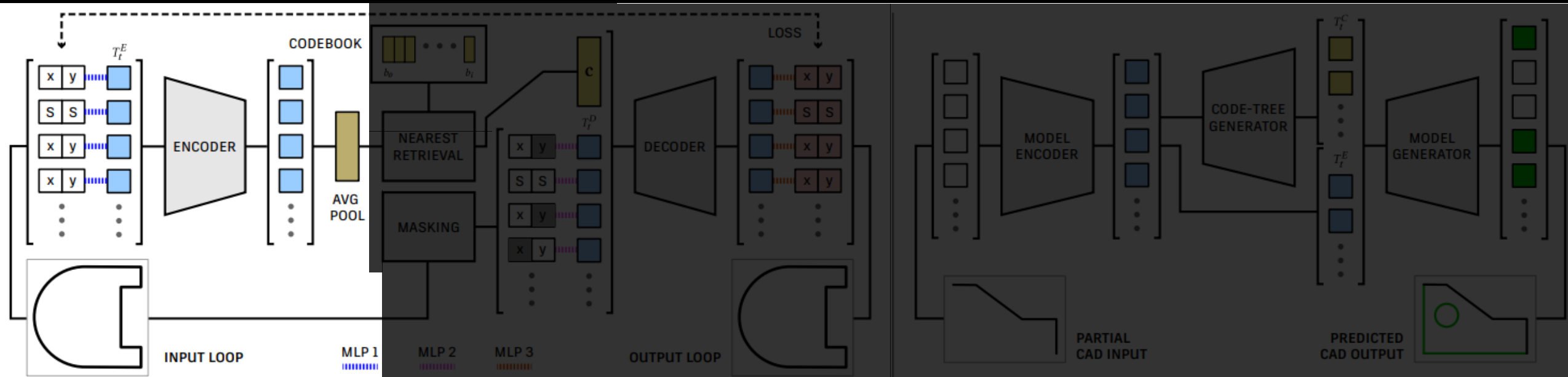

Three-Level Codebook Learning

- Encoder
- Masked skip connection
- Decoder

Controllable CAD Generation

- Model Encoder
- Code-Tree Generator
- Model Generator

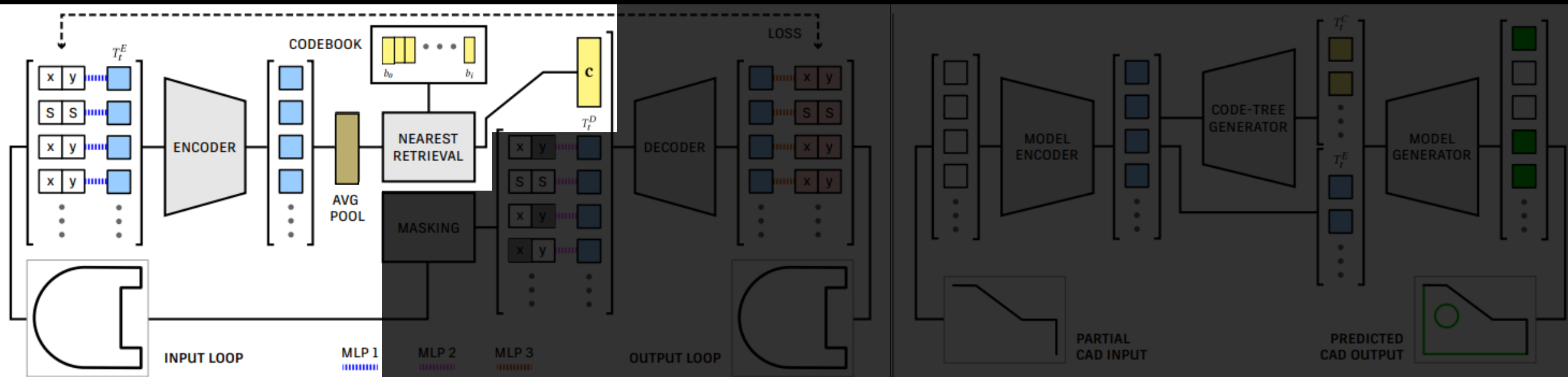

Three-Level Codebook Learning

- Encoder
- Masked skip connection
- Decoder

Controllable CAD Generation

- Model Encoder
- Code-Tree Generator
- Model Generator

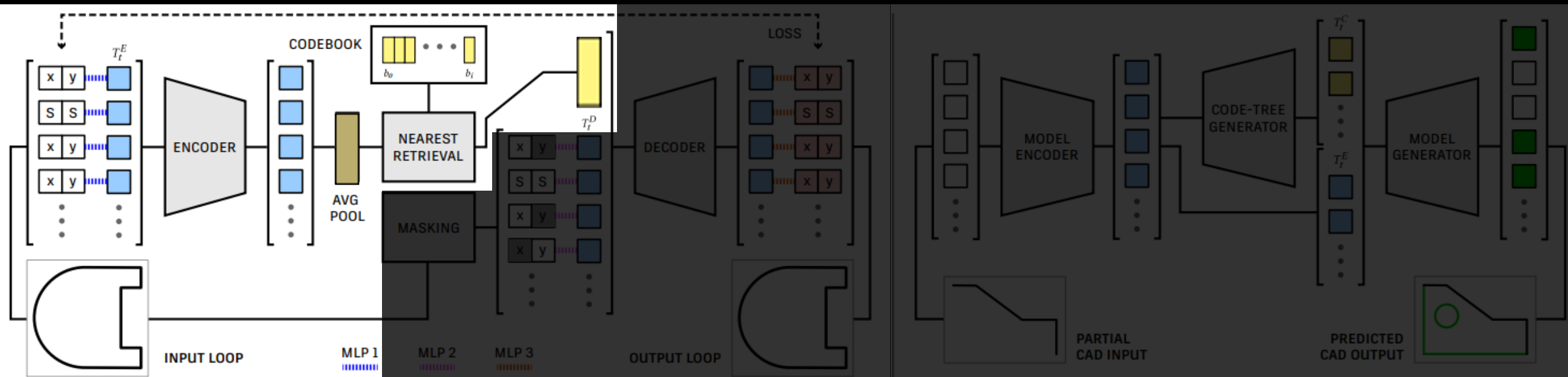

Three-Level Codebook Learning

- Encoder
- Masked skip connection
- Decoder

Controllable CAD Generation

- Model Encoder
- Code-Tree Generator
- Model Generator

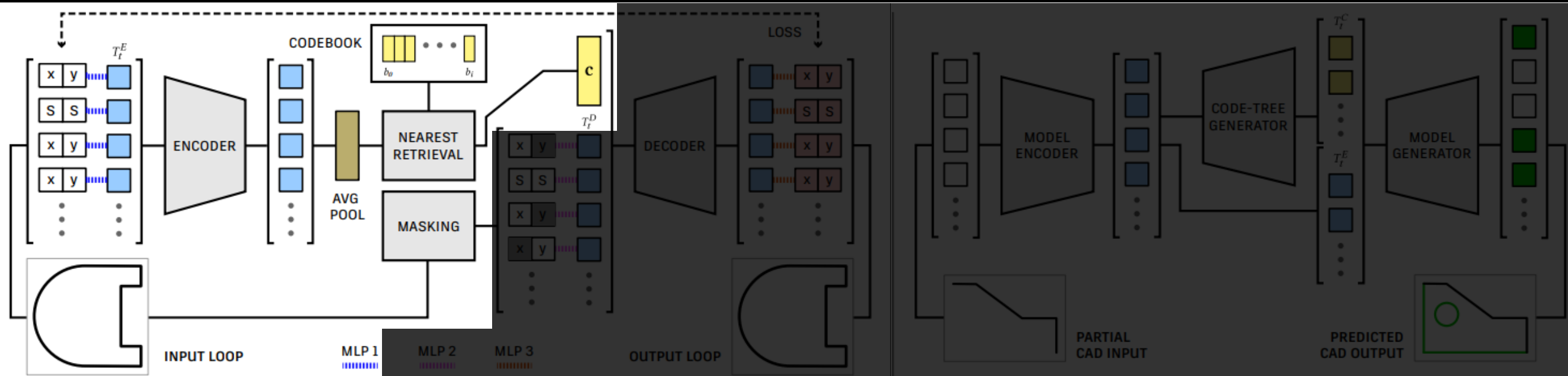

Three-Level Codebook Learning

- Encoder
- Masked skip connection
- Decoder

Controllable CAD Generation

- Model Encoder
- Code-Tree Generator
- Model Generator

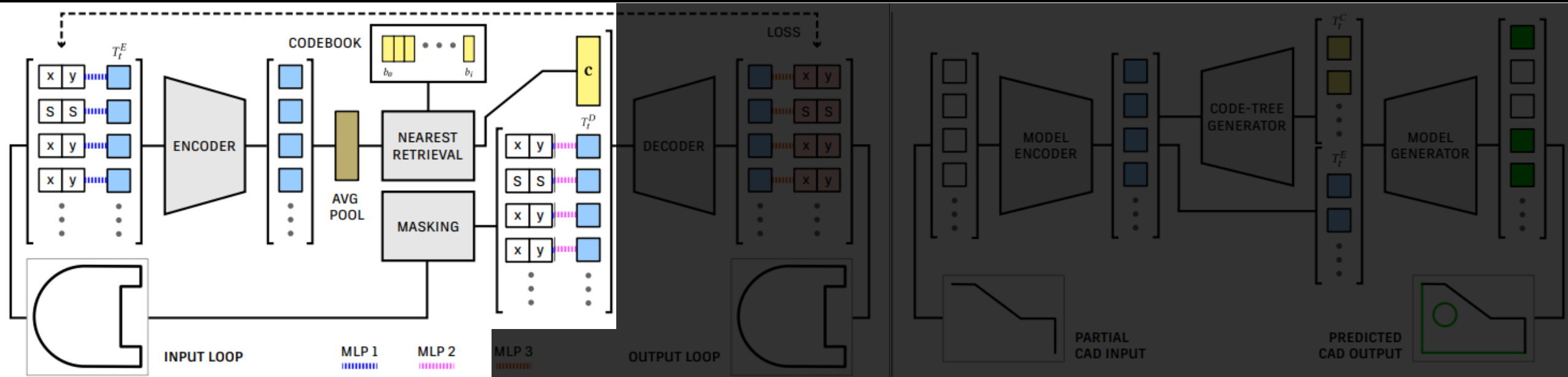

Three-Level Codebook Learning

- Encoder
- Masked skip connection
- Decoder

Controllable CAD Generation

- Model Encoder
- Code-Tree Generator
- Model Generator

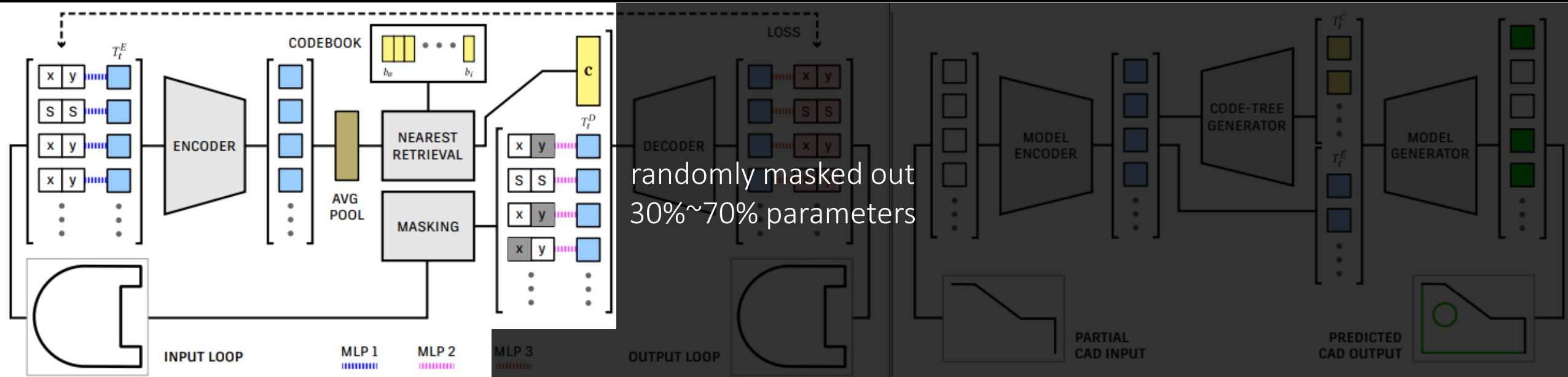

Three-Level Codebook Learning

- Encoder
- Masked skip connection
- Decoder

Controllable CAD Generation

- Model Encoder
- Code-Tree Generator
- Model Generator

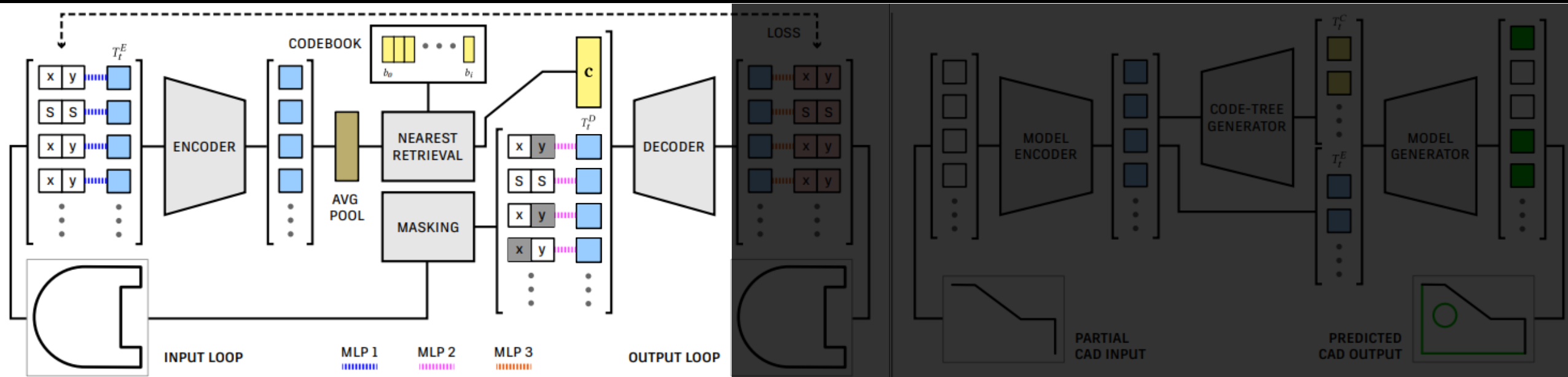

Three-Level Codebook Learning

- Encoder
- Masked skip connection
- Decoder

Controllable CAD Generation

- Model Encoder
- Code-Tree Generator
- Model Generator

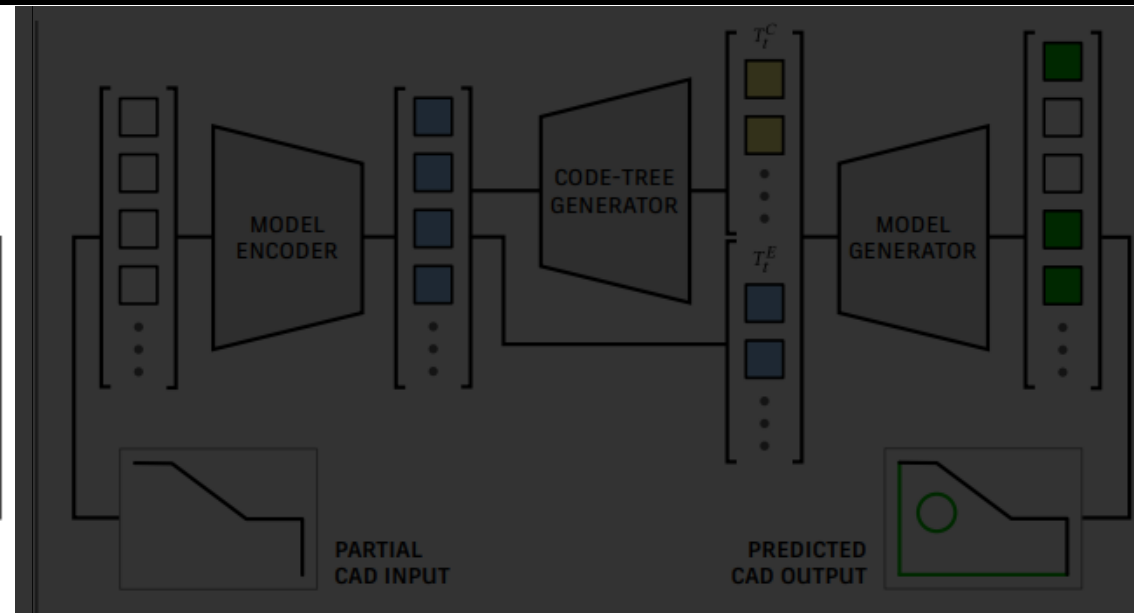
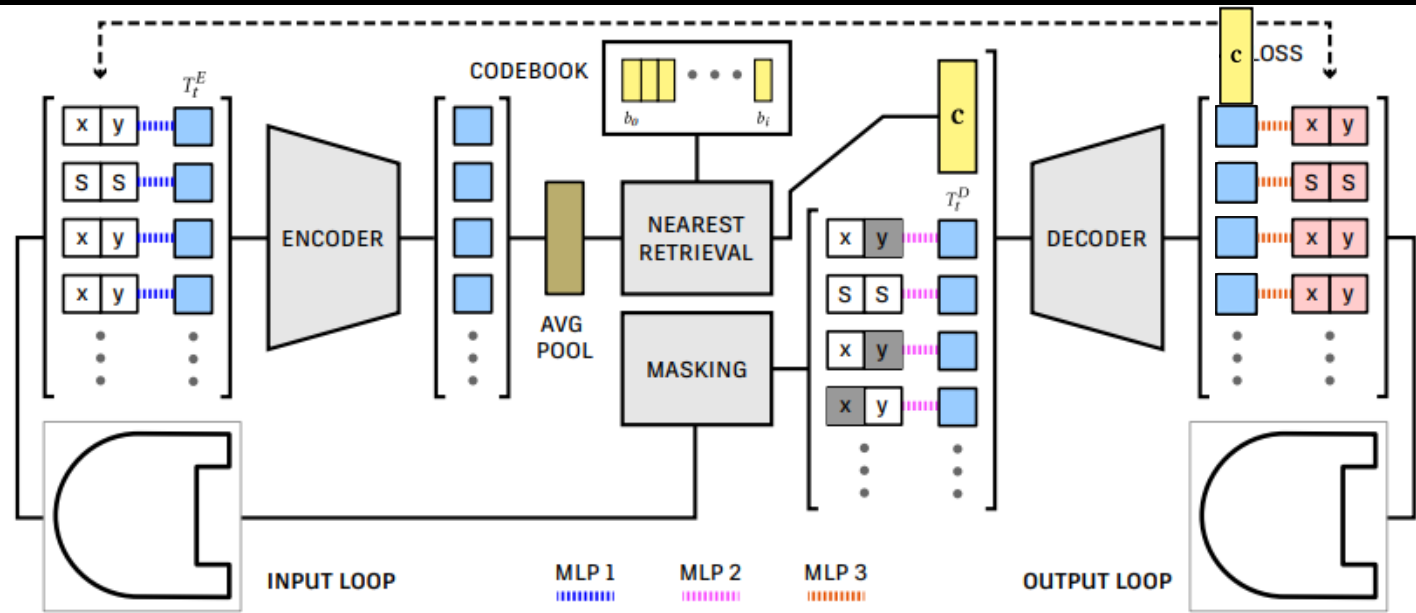

Three-Level Codebook Learning

- Encoder
- Masked skip connection
- Decoder

Controllable CAD Generation

- Model Encoder
- Code-Tree Generator
- Model Generator

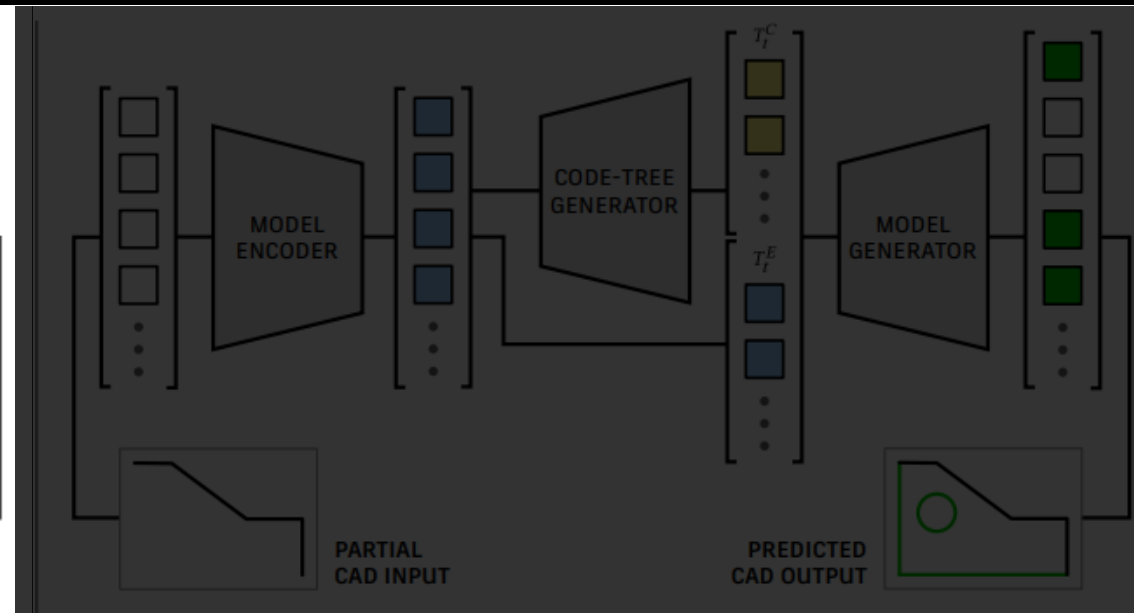
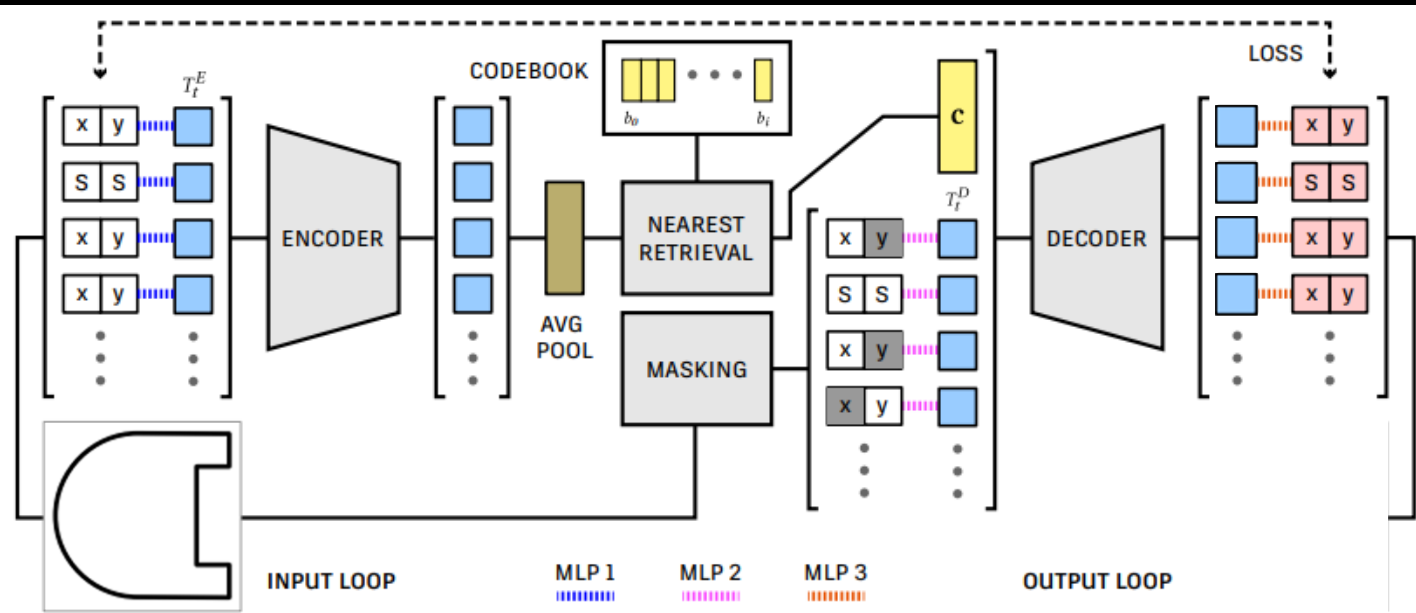

Three-Level Codebook Learning

- Encoder
- Masked skip connection
- Decoder

Controllable CAD Generation

- Model Encoder
- Code-Tree Generator
- Model Generator

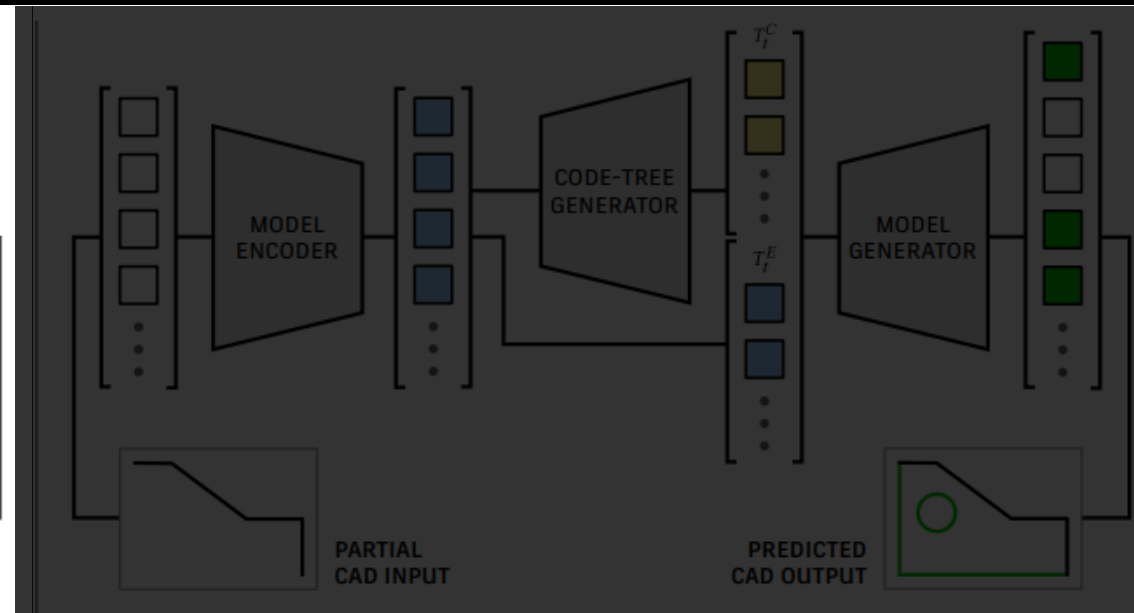
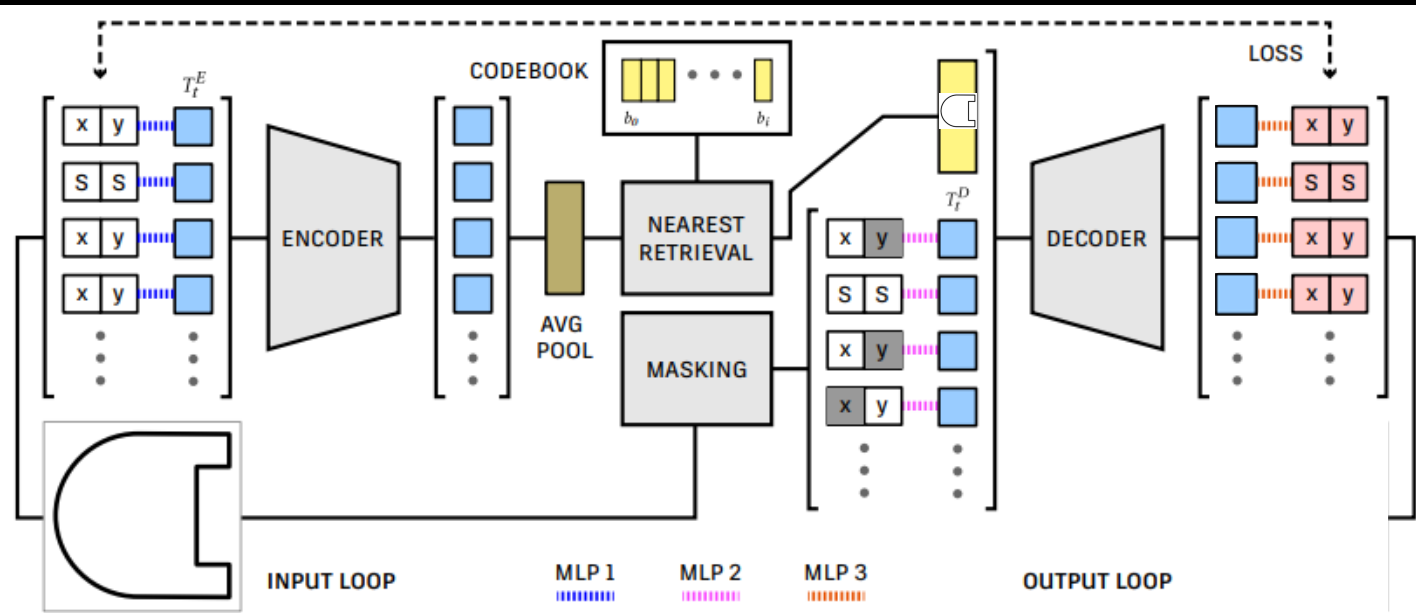

Three-Level Codebook Learning

- Encoder
- Masked skip connection
- Decoder

Controllable CAD Generation

- Model Encoder
- Code-Tree Generator
- Model Generator

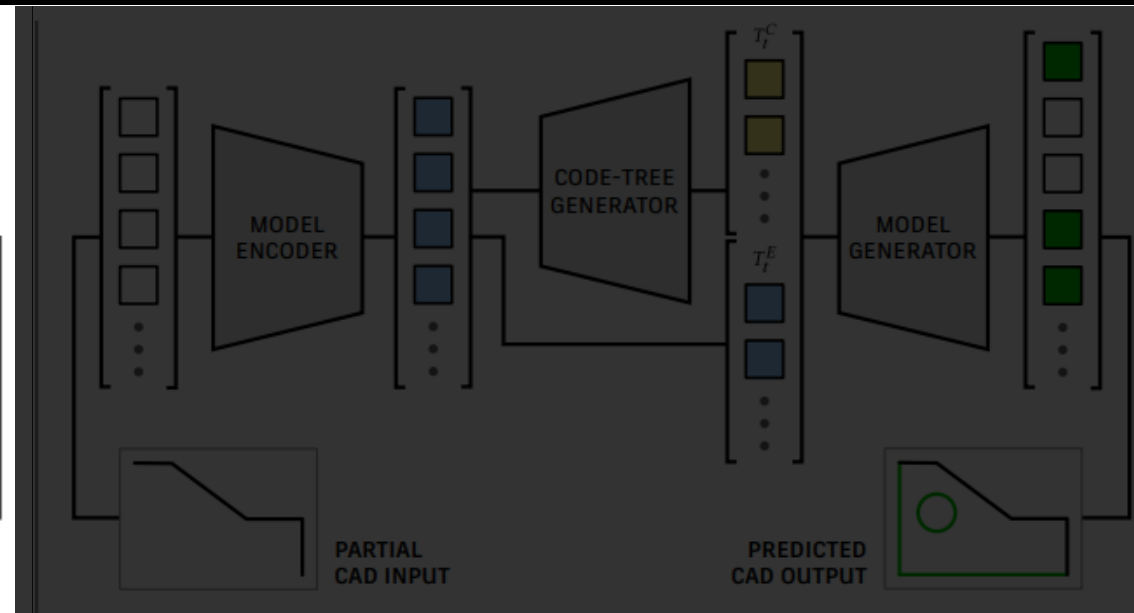
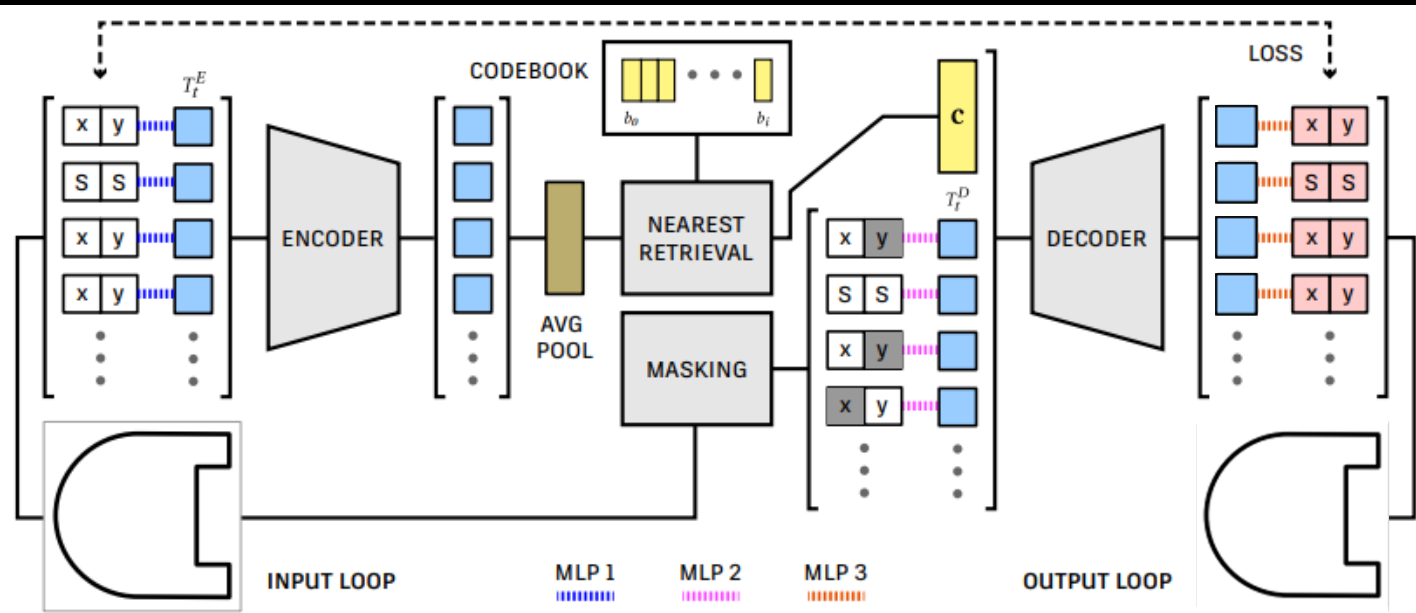

Three-Level Codebook Learning

- Encoder
- Masked skip connection
- Decoder

Controllable CAD Generation

- Model Encoder
- Code-Tree Generator
- Model Generator

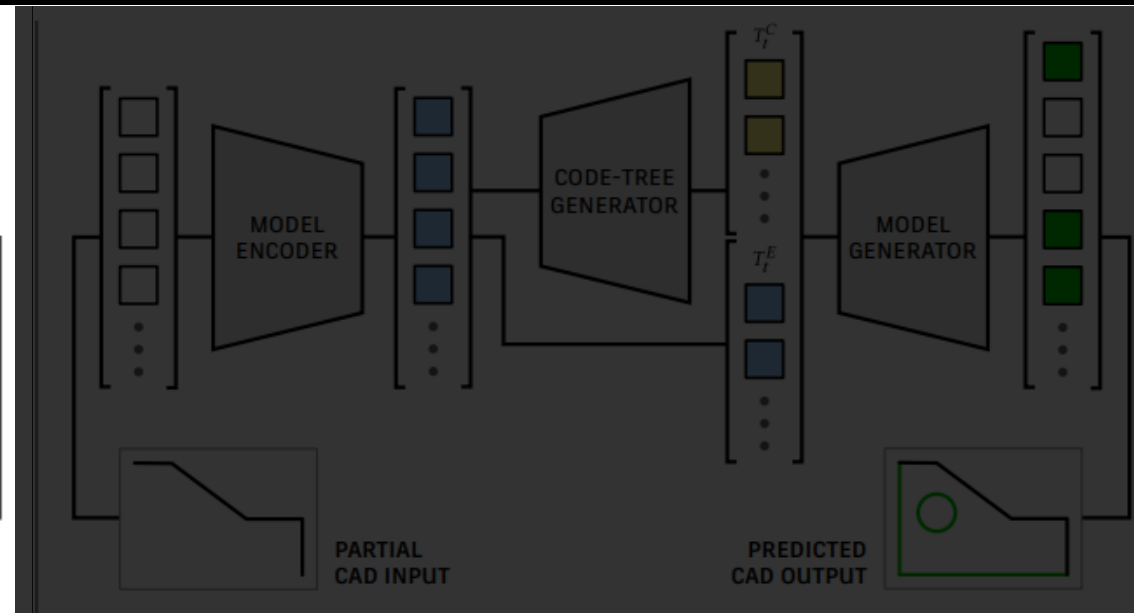
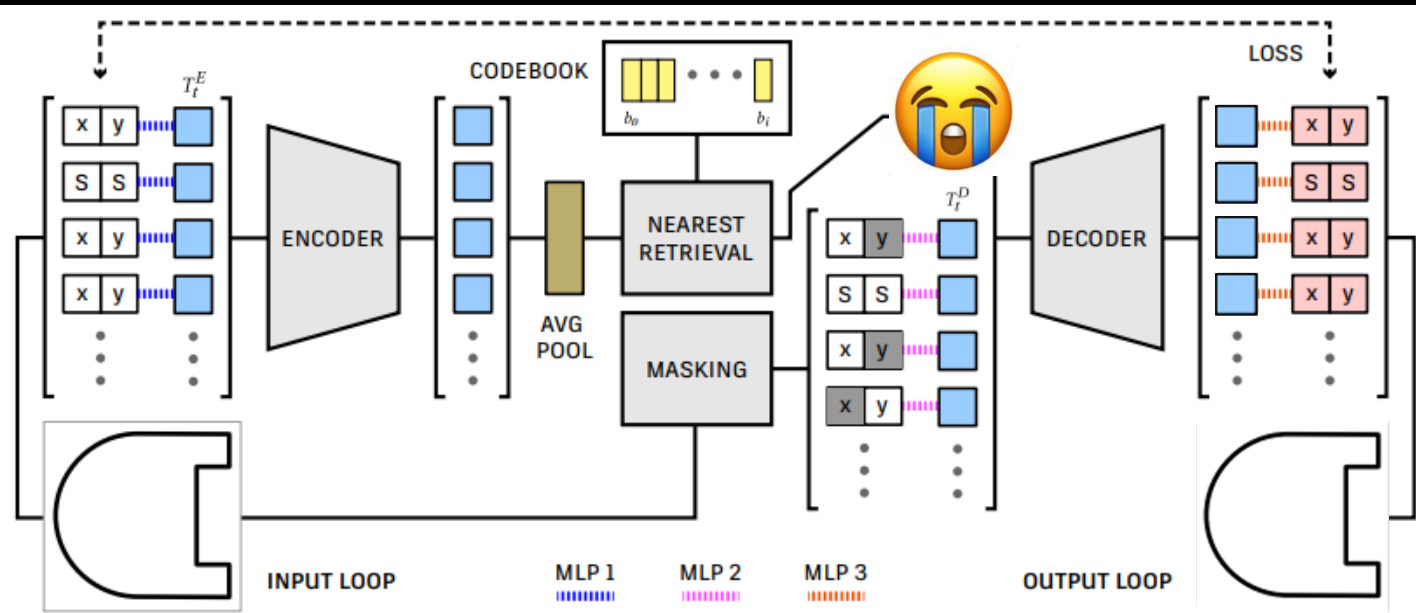

Three-Level Codebook Learning

- Encoder
- Masked skip connection
- Decoder

Controllable CAD Generation

- Model Encoder
- Code-Tree Generator
- Model Generator

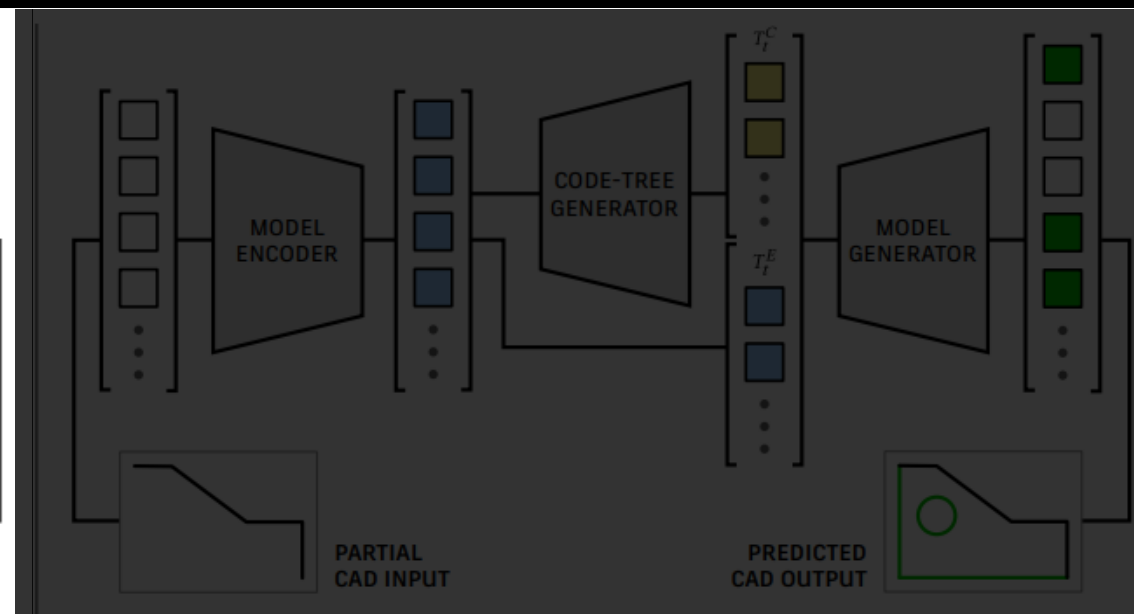
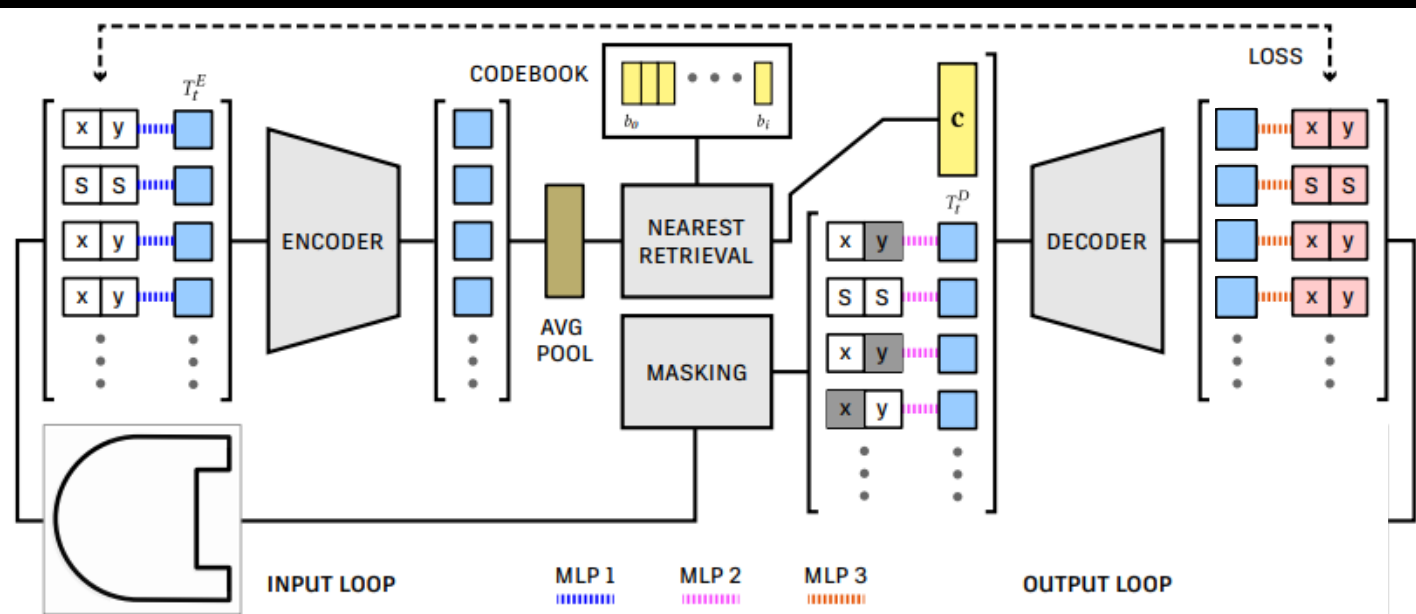

Three-Level Codebook Learning

- Encoder
- Masked skip connection
- Decoder

Controllable CAD Generation

- Model Encoder
- Code-Tree Generator
- Model Generator

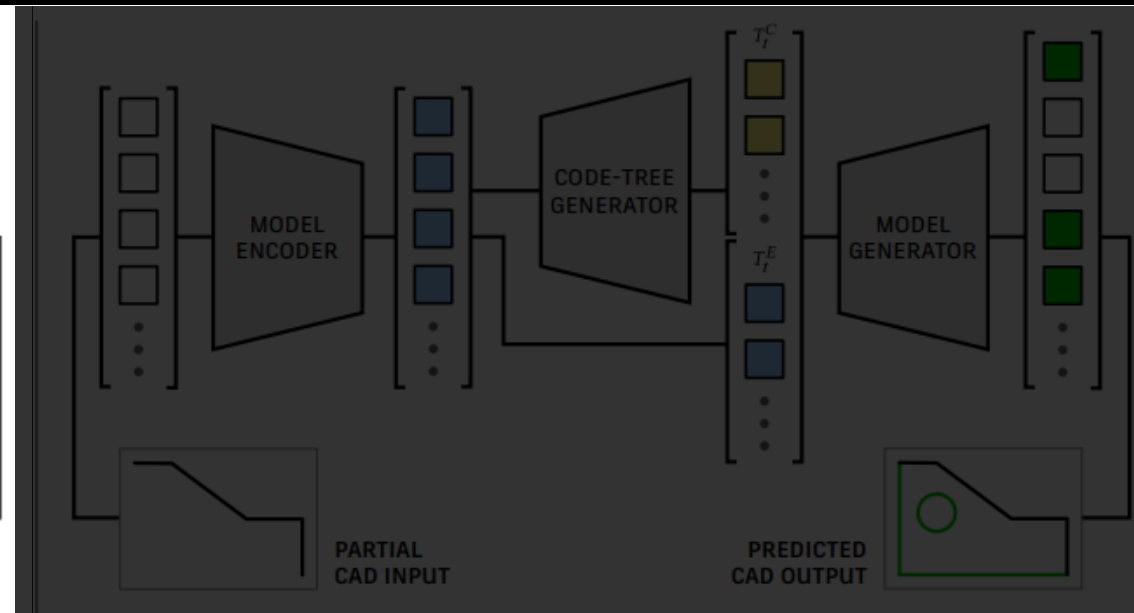
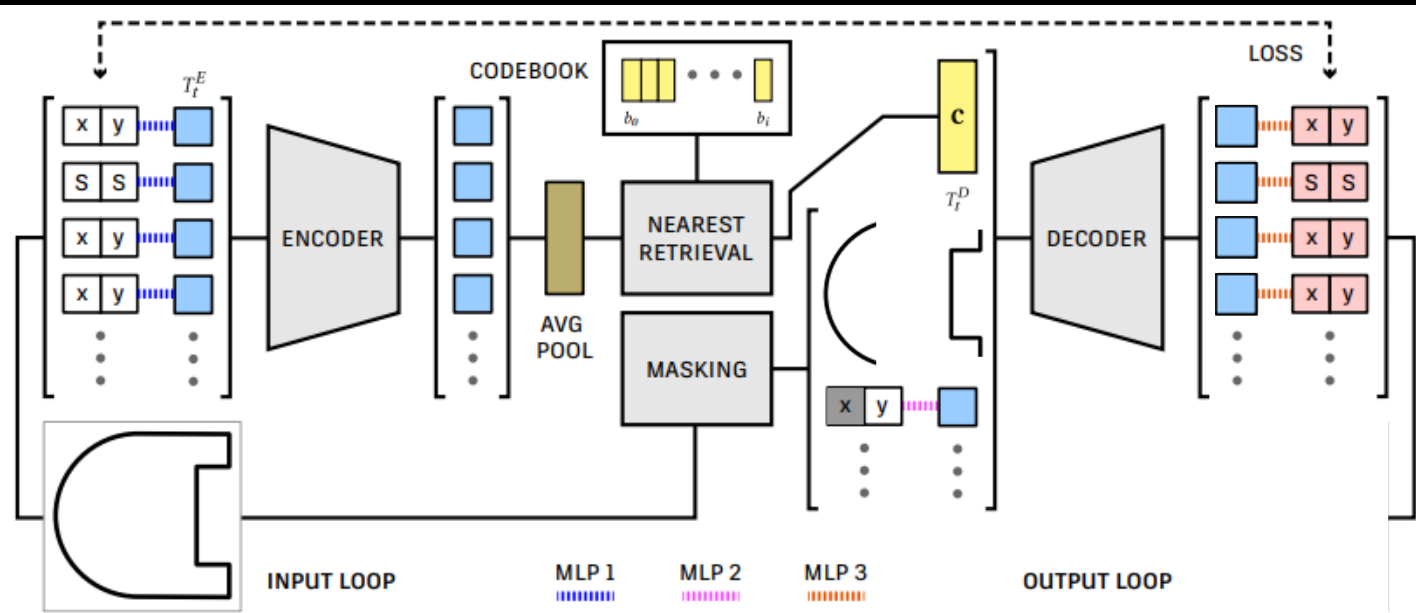

Three-Level Codebook Learning

- Encoder
- Masked skip connection
- Decoder

Controllable CAD Generation

- Model Encoder
- Code-Tree Generator
- Model Generator

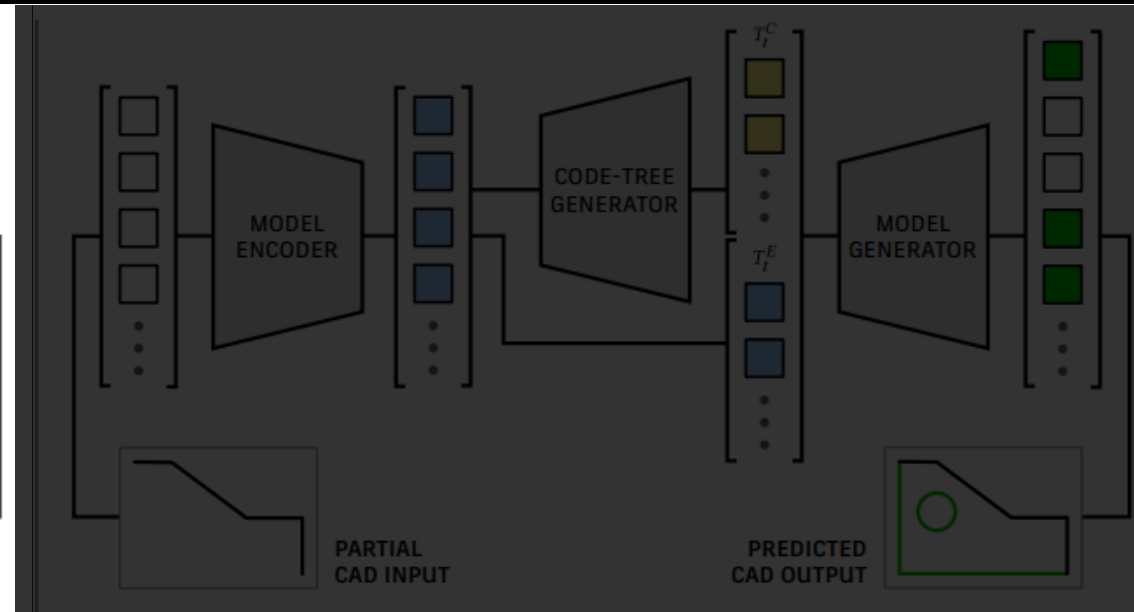
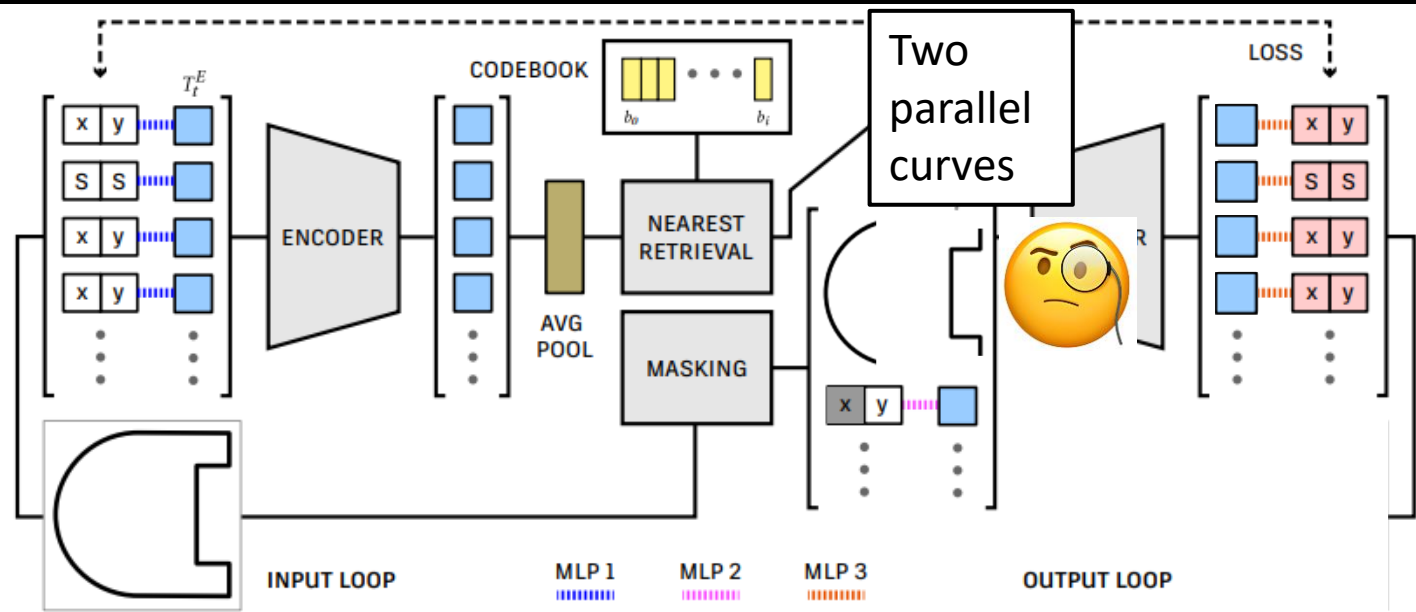

Three-Level Codebook Learning

- Encoder
- Masked skip connection
- Decoder

Controllable CAD Generation

- Model Encoder
- Code-Tree Generator
- Model Generator

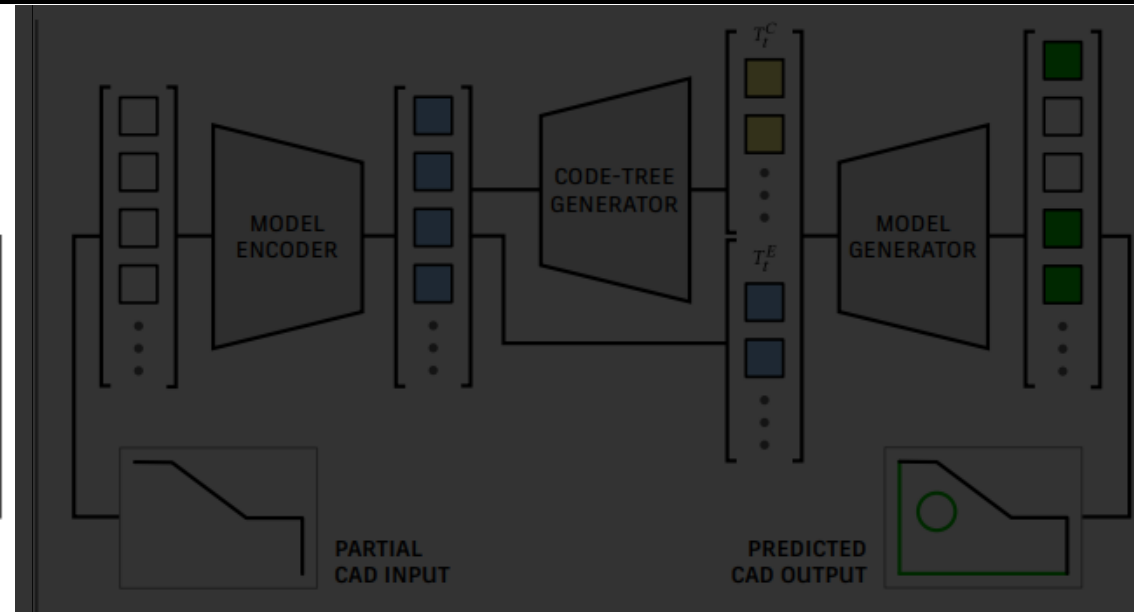
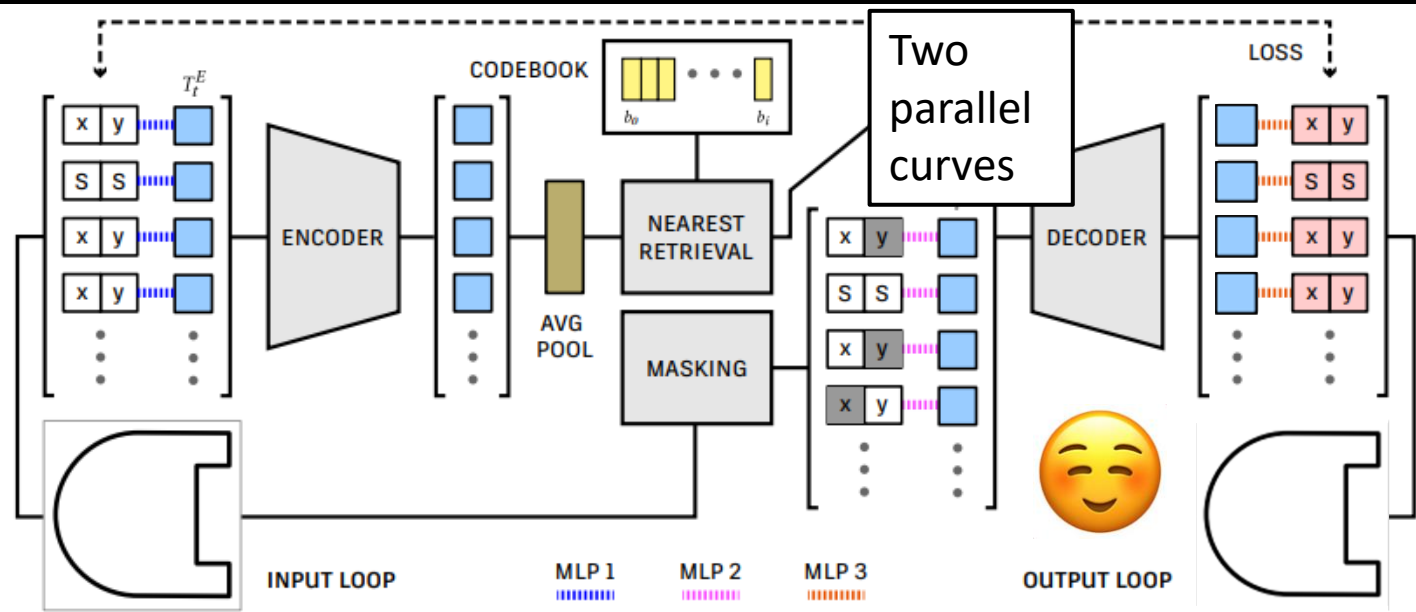

Three-Level Codebook Learning

- Encoder
- Masked skip connection
- Decoder

Controllable CAD Generation

- Model Encoder
- Code-Tree Generator
- Model Generator

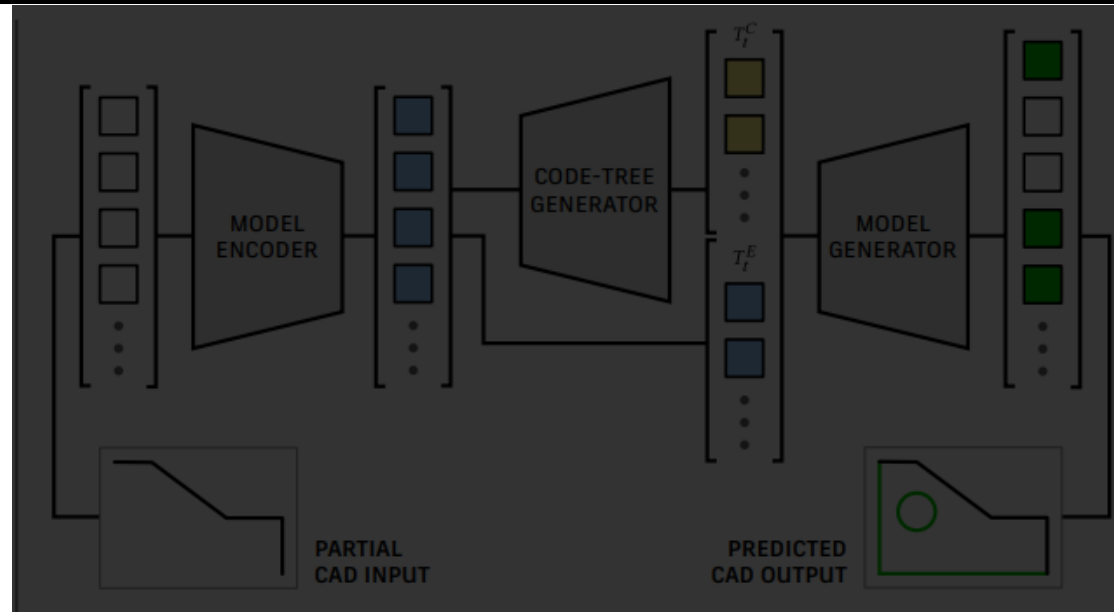
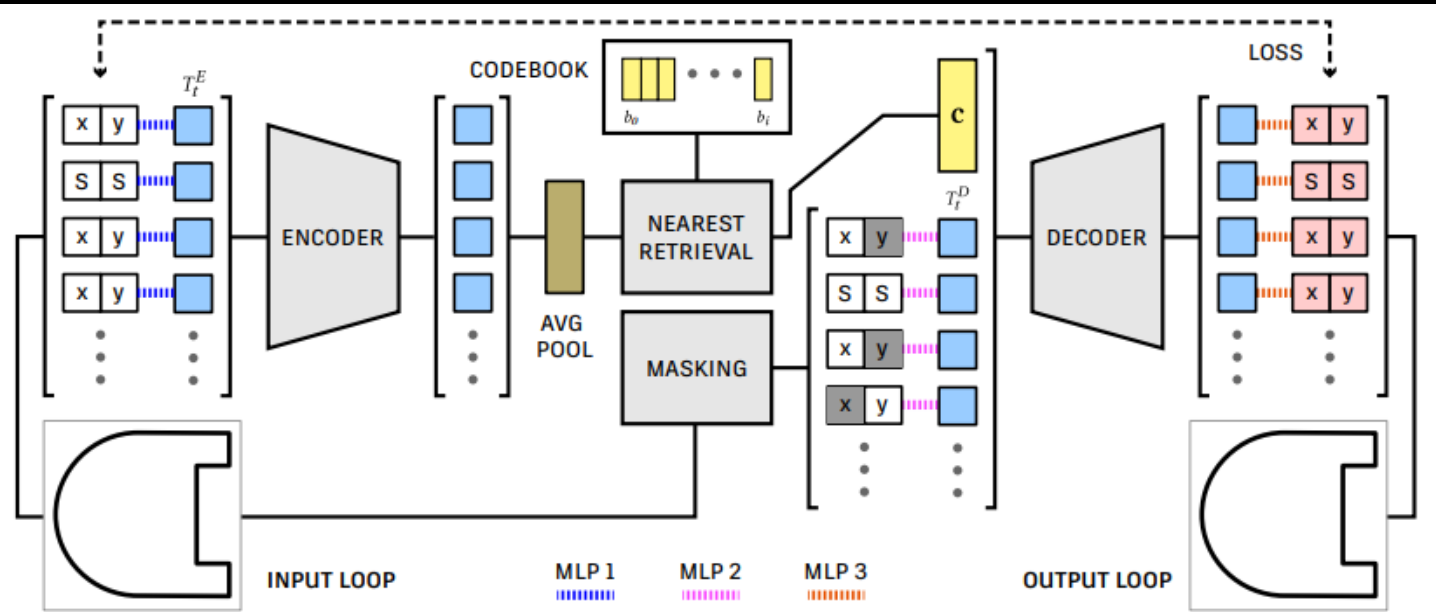

$$\sum_t \text{EMD}(D(\mathbf{c}, \{T_t^D\}), \mathbb{1}_{T_t^E}) +$$

$$\|sg[\bar{E}(T^E)] - \mathbf{c}\|_2^2 + \beta \|\bar{E}(T^E) - sg[\mathbf{c}]\|_2^2$$

Three-Level Codebook Learning

- Encoder
- Masked skip connection
- Decoder

Controllable CAD Generation

- Model Encoder
- Code-Tree Generator
- Model Generator

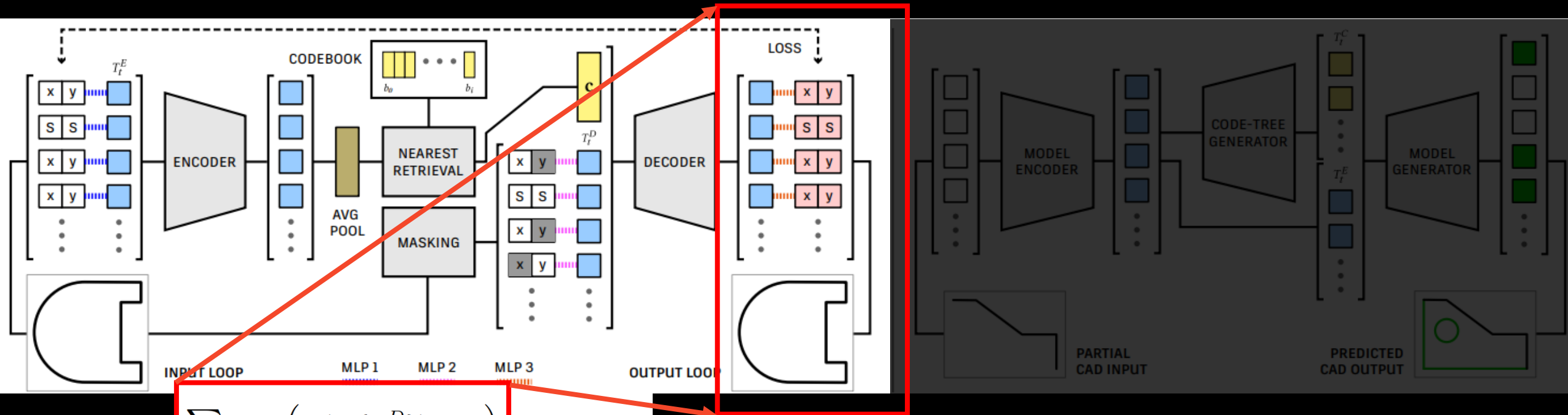

$$\sum_t \text{EMD}(D(\mathbf{c}, \{T_t^D\}), \mathbb{1}_{T_t}) + \left\| \text{sg}[\overline{E}(T^E)] - \mathbf{c} \right\|_2^2 + \beta \left\| \overline{E}(T^E) - \text{sg}[\mathbf{c}] \right\|_2^2$$

Reconstruction Loss
(Earth Mover's Distance)

Three-Level Codebook Learning

- Encoder
- Masked skip connection
- Decoder

Controllable CAD Generation

- Model Encoder
- Code-Tree Generator
- Model Generator

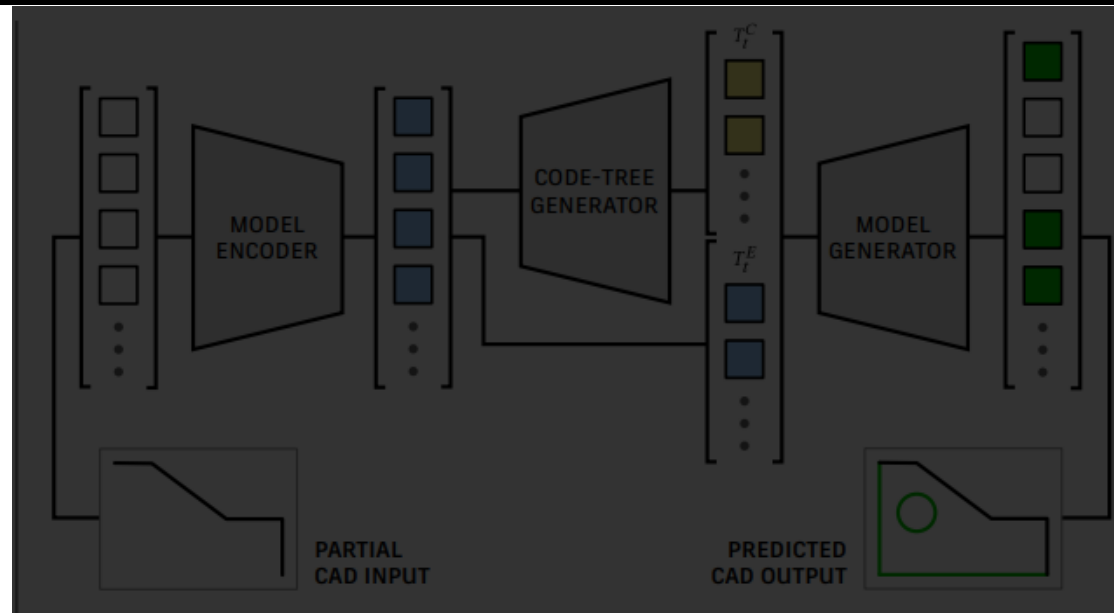
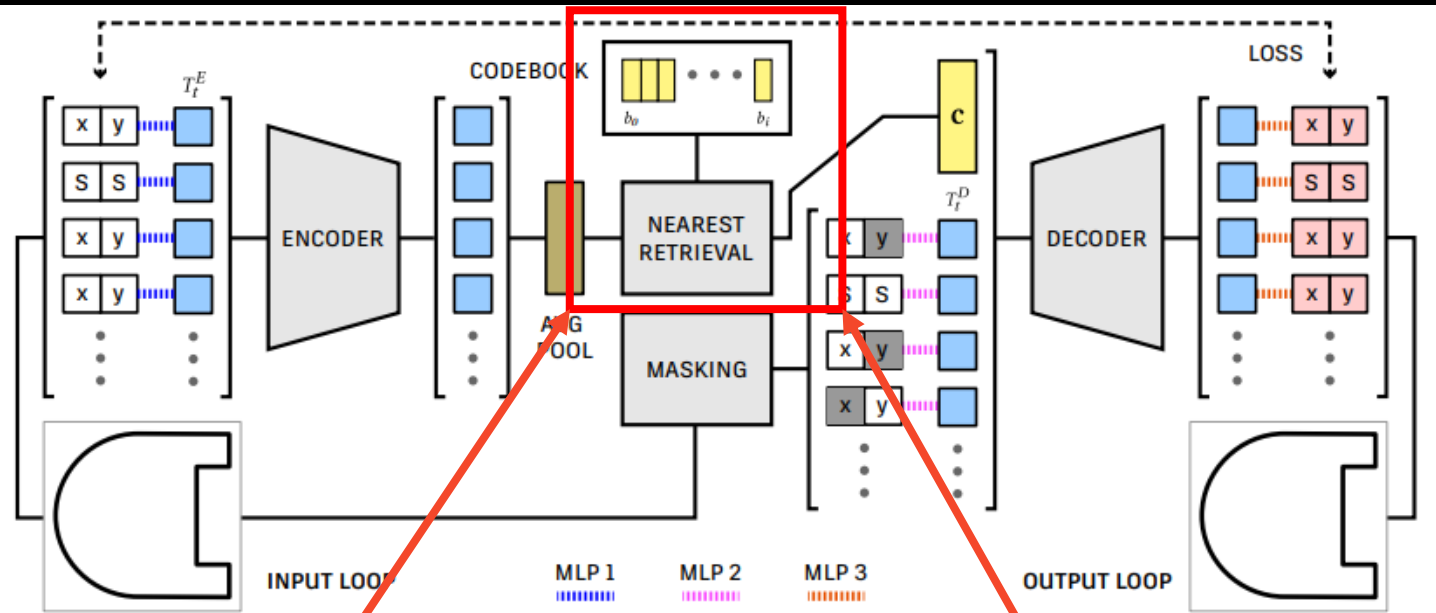

$$\sum_t \text{EMD}(D(\mathbf{c}, \{T_t^D\}), \mathbb{1}_{T_t}) +$$

$$\|sg[\bar{E}(T^E)] - \mathbf{c}\|_2^2 + \beta \|\bar{E}(T^E) - sg[\mathbf{c}]\|_2^2$$

Codebook Losses

Three-Level Codebook Learning

- Encoder
- Masked skip connection
- Decoder

Controllable CAD Generation

- Model Encoder
- Code-Tree Generator
- Model Generator

Loop – Profile – Solid Tree

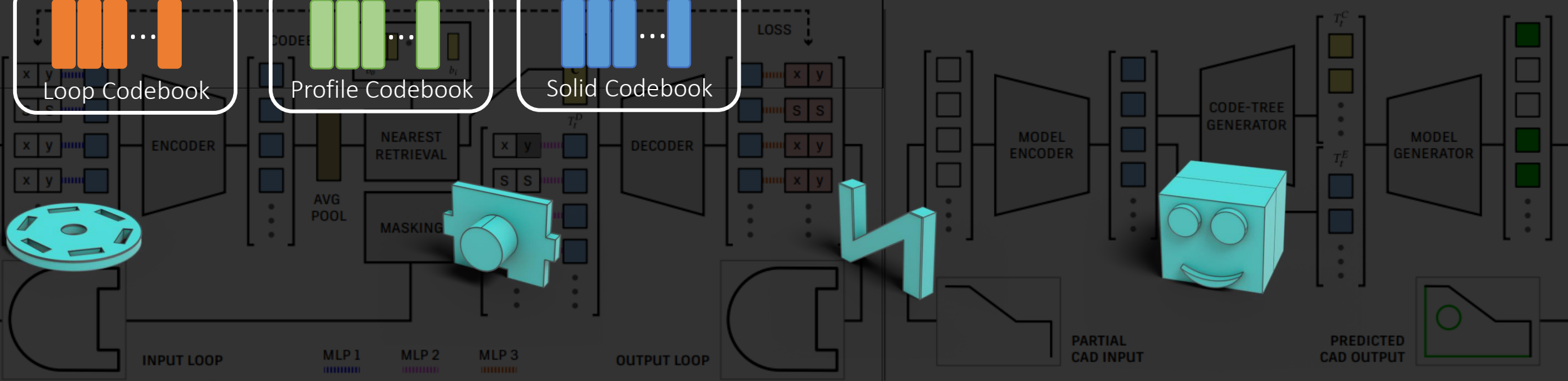
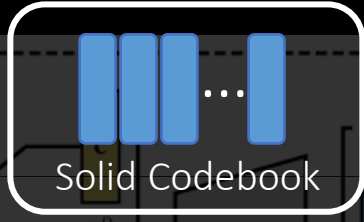
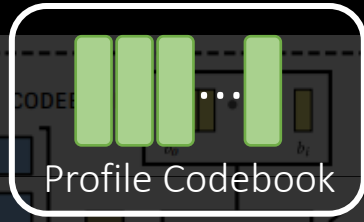

Three-Level Codebook Learning

- Encoder
- Masked skip connection
- Decoder

Controllable CAD Generation

- Model Encoder
- Code-Tree Generator
- Model Generator

Loop – Profile – Solid Tree

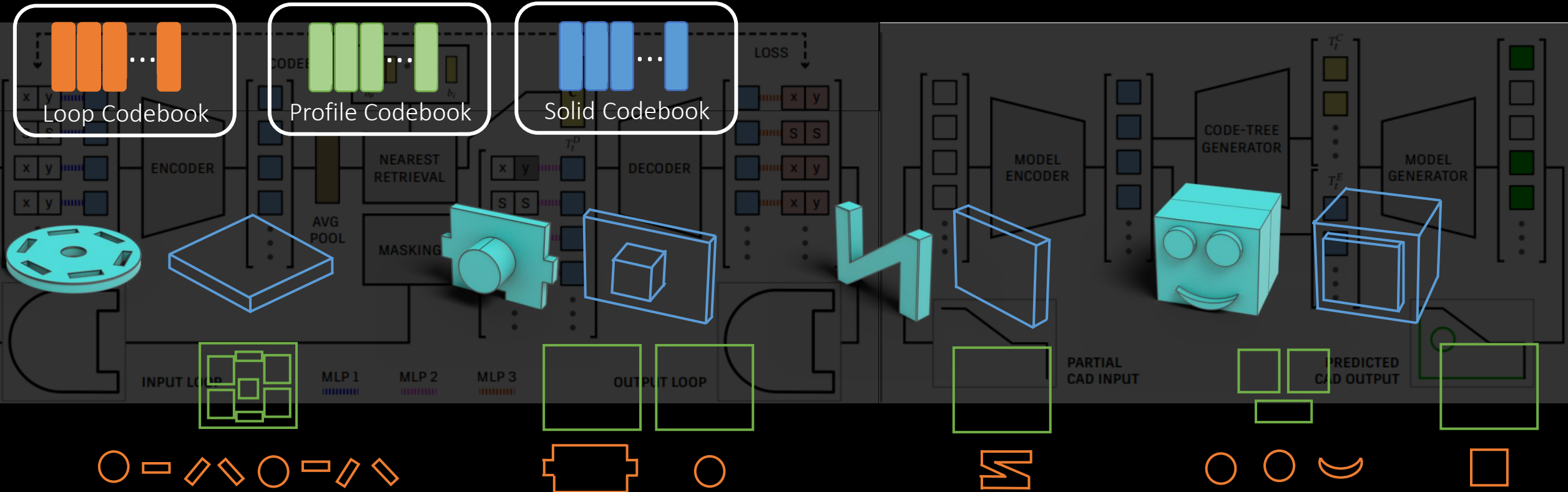

Three-Level Codebook Learning

- Encoder
- Masked skip connection
- Decoder

Controllable CAD Generation

- Model Encoder
- Code-Tree Generator
- Model Generator

Three-Level Code Tree

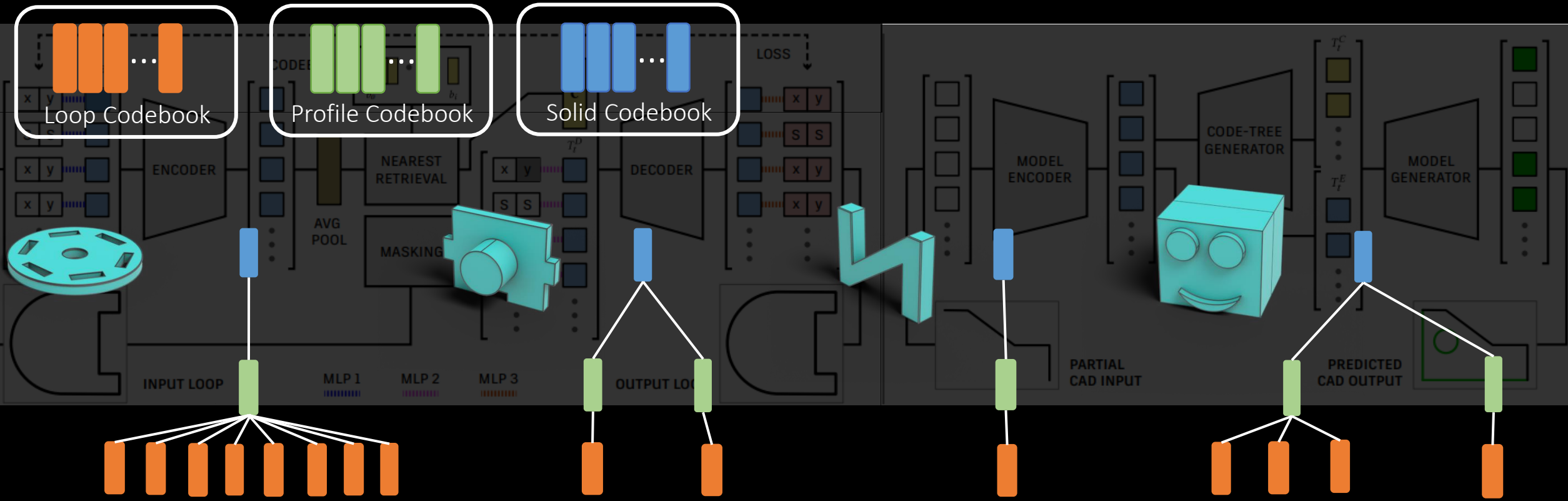

Three-Level Codebook Learning

- Encoder
- Masked skip connection
- Decoder

Controllable CAD Generation

- Model Encoder
- Code-Tree Generator
- Model Generator

Flatten Code Tree (depth first traverse)

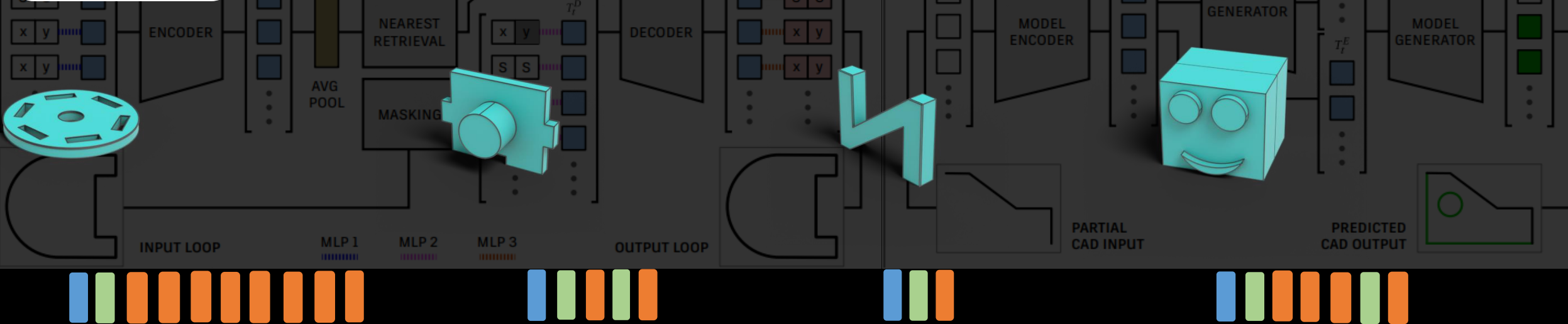
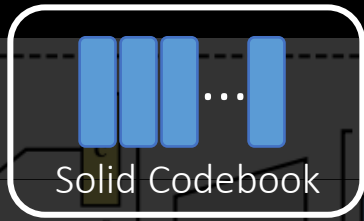
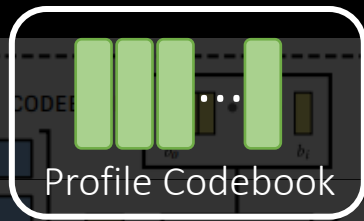

Three-Level Codebook Learning

- Encoder
- Masked skip connection
- Decoder

Controllable CAD Generation

- Model Encoder
- Code-Tree Generator
- Model Generator

Flatten Code Tree (depth first traverse)

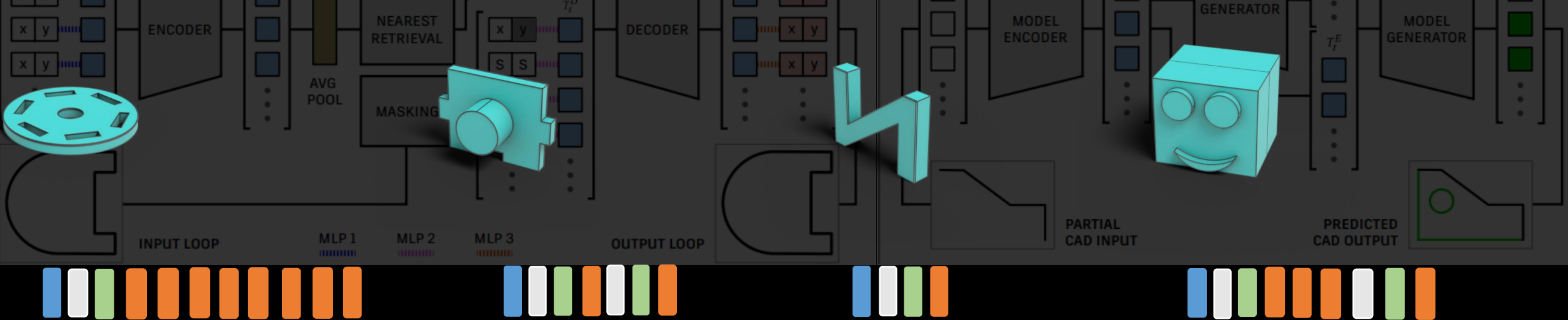
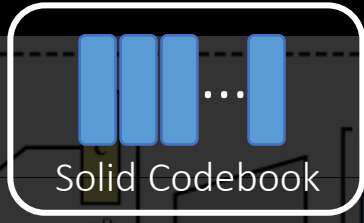
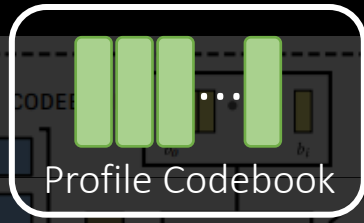
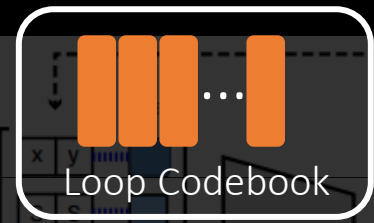

Three-Level Codebook Learning

- Encoder
- Masked skip connection
- Decoder

Controllable CAD Generation

- Model Encoder
- Code-Tree Generator
- Model Generator

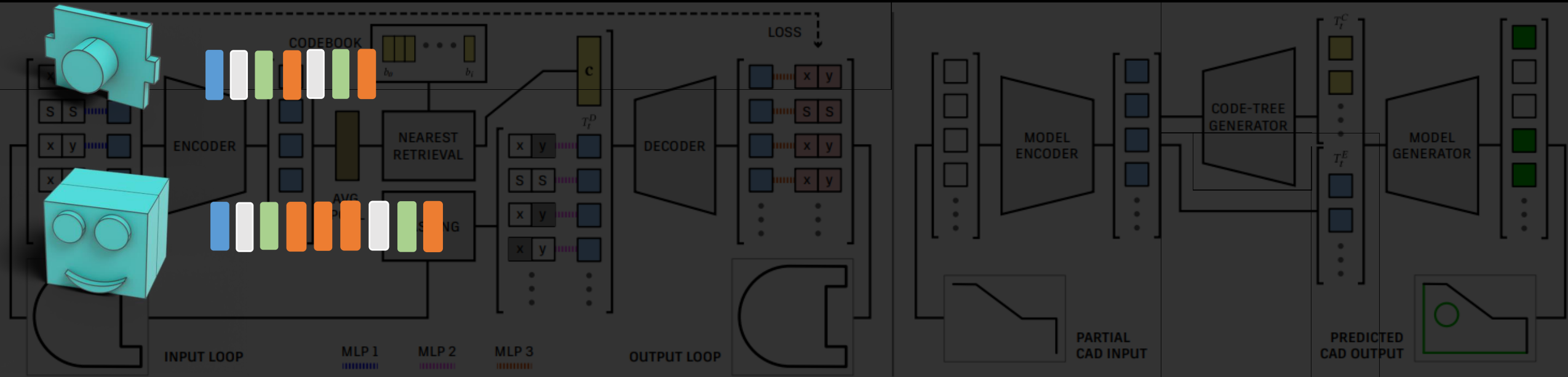

Three-Level Codebook Learning

- Encoder
- Masked skip connection
- Decoder

Controllable CAD Generation

- Model Encoder
- Code-Tree Generator
- Model Generator

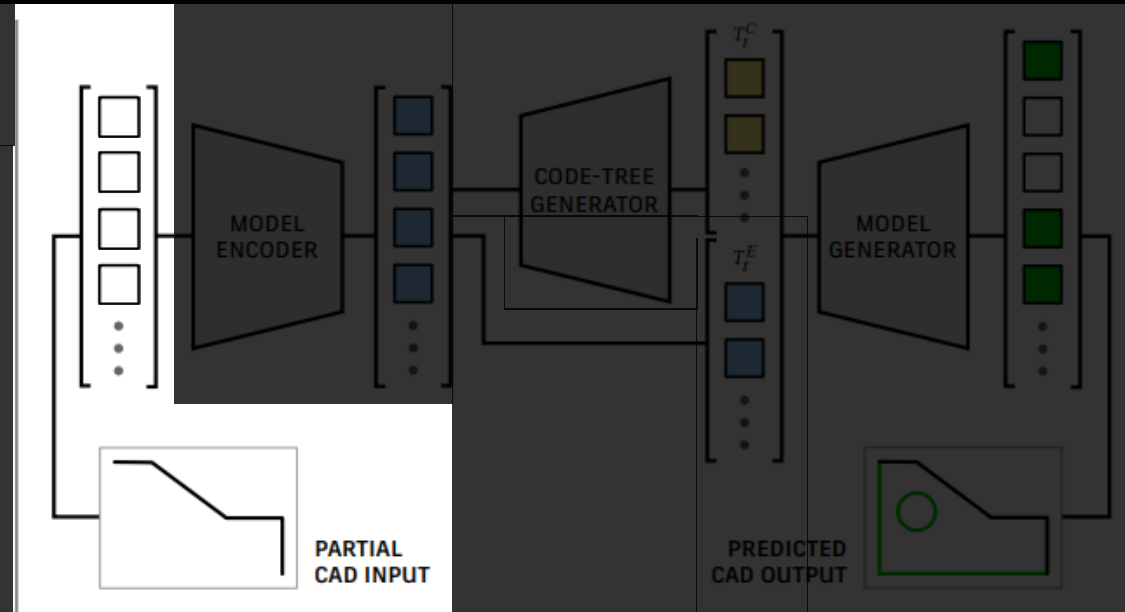
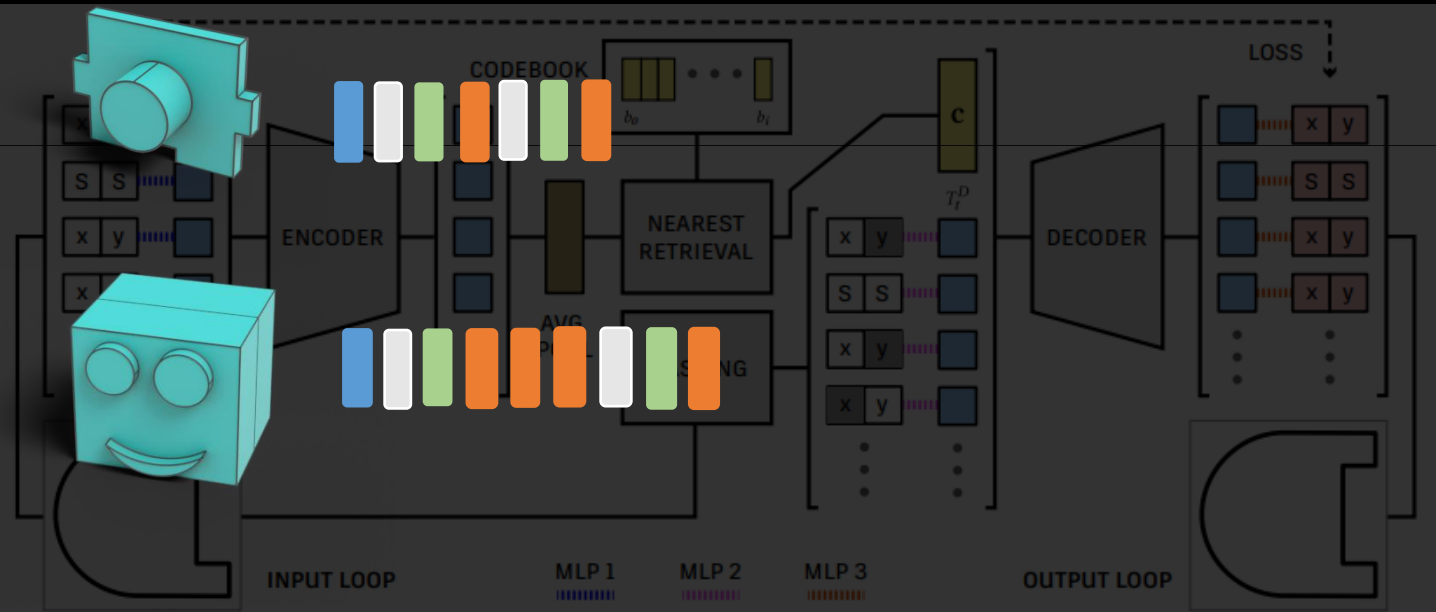

Three-Level Codebook Learning

- Encoder
- Masked skip connection
- Decoder

Controllable CAD Generation

- **Model Encoder**
- Code-Tree Generator
- Model Generator

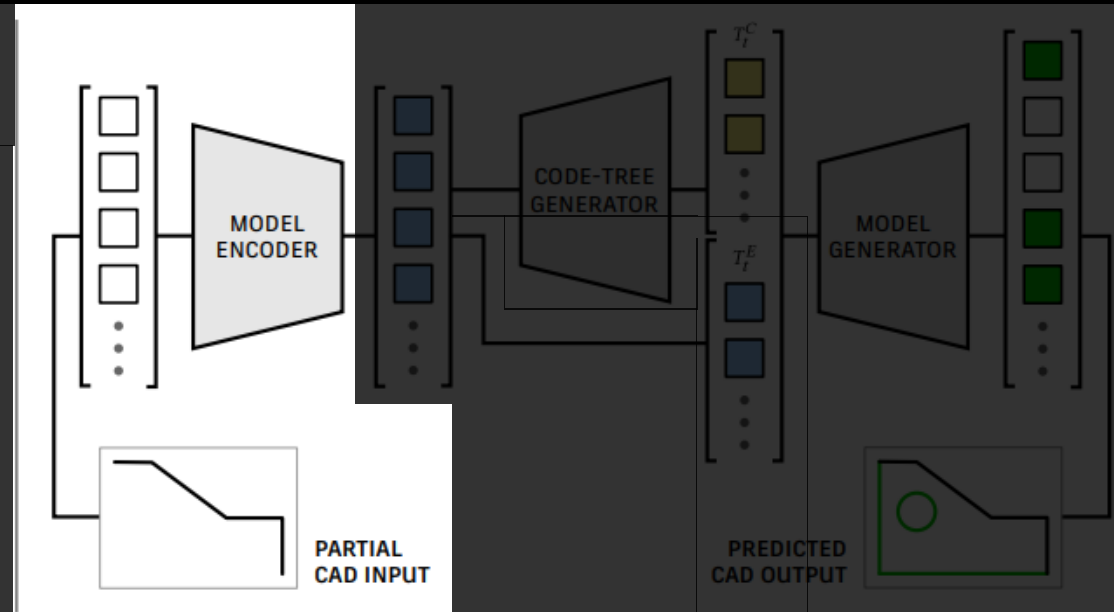
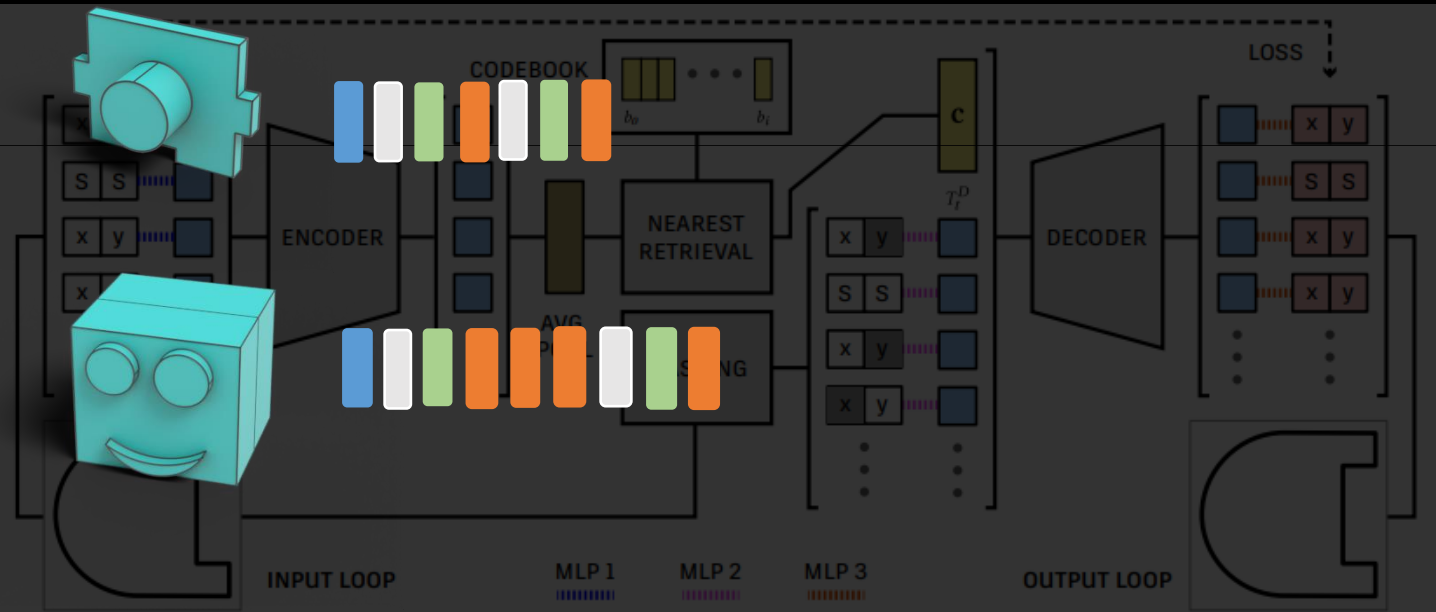

Three-Level Codebook Learning

- Encoder
- Masked skip connection
- Decoder

Controllable CAD Generation

- **Model Encoder**
- Code-Tree Generator
- Model Generator

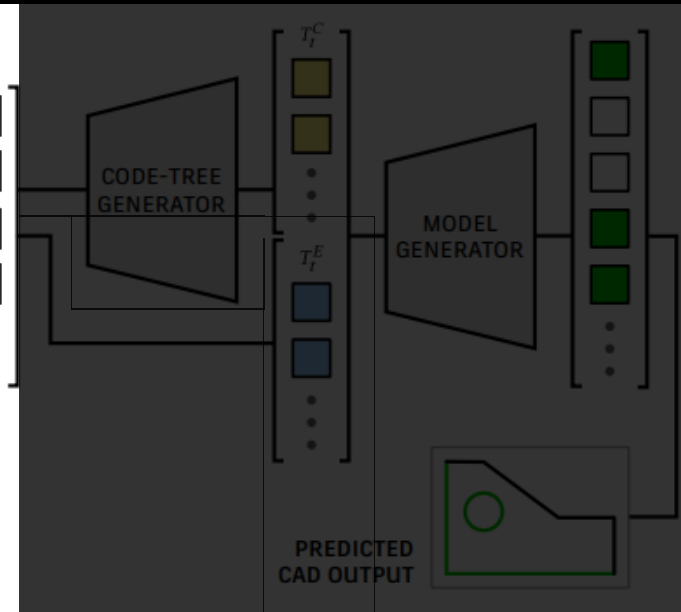
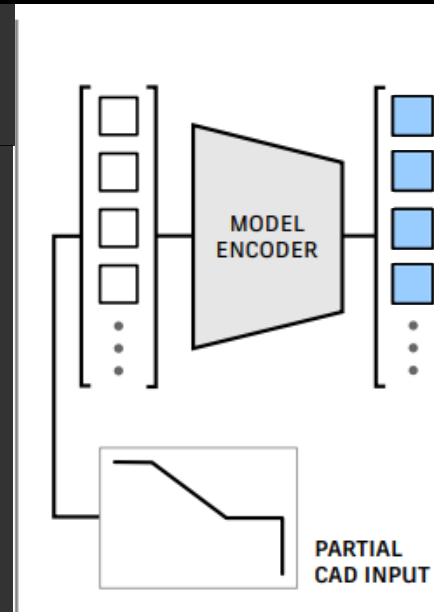
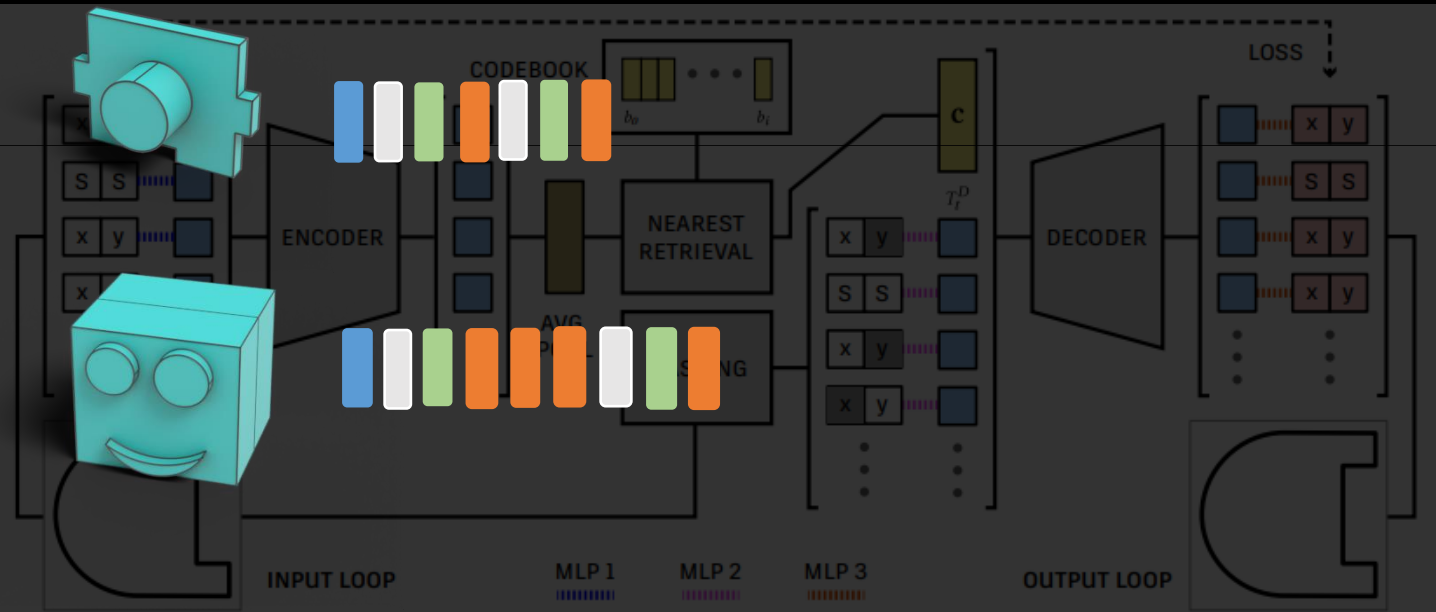

Three-Level Codebook Learning

- Encoder
- Masked skip connection
- Decoder

Controllable CAD Generation

- **Model Encoder**
- Code-Tree Generator
- Model Generator

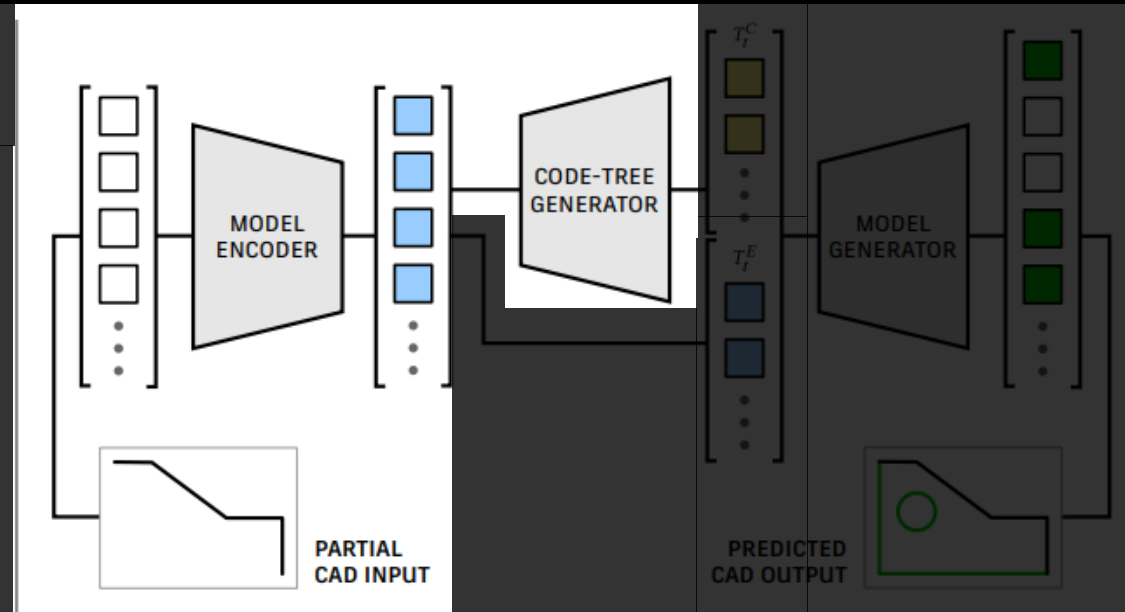
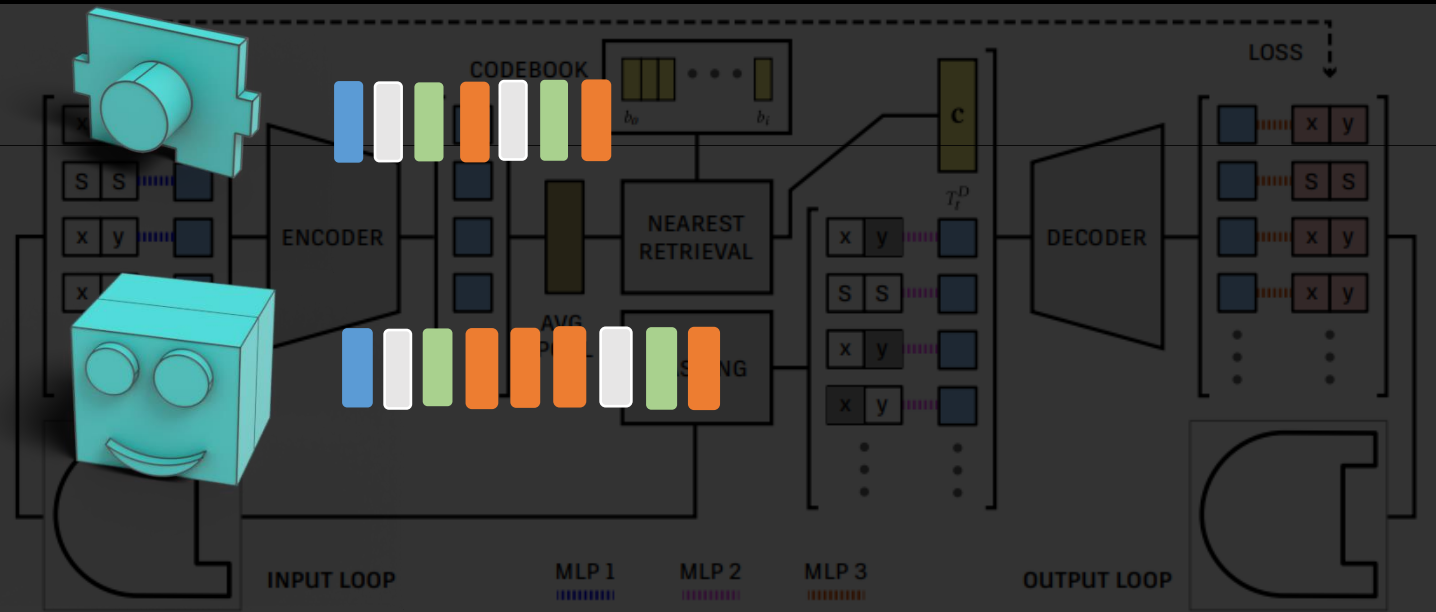

Three-Level Codebook Learning

- Encoder
- Masked skip connection
- Decoder

Controllable CAD Generation

- Model Encoder
- Code-Tree Generator
- Model Generator

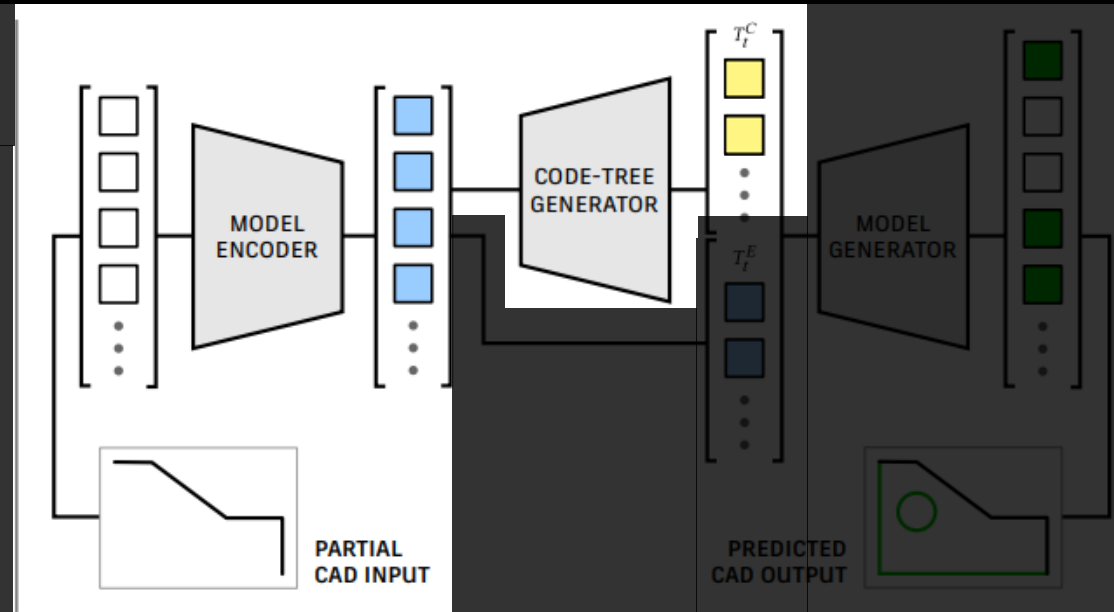
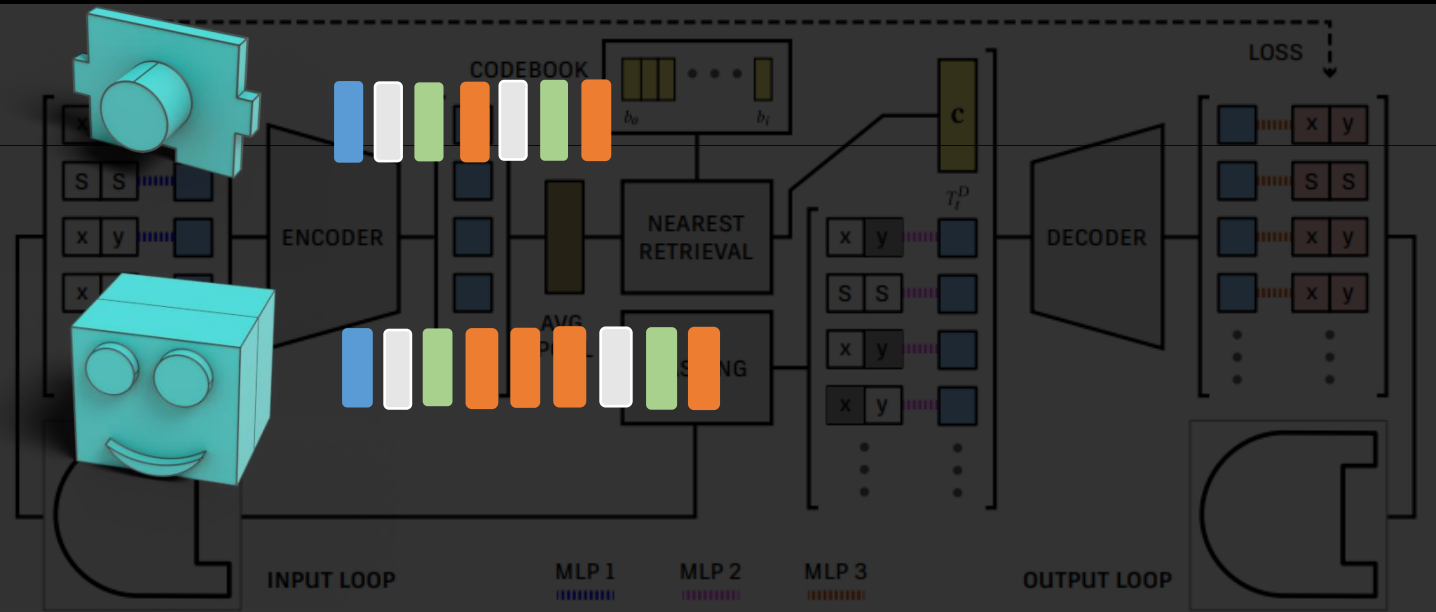

Three-Level Codebook Learning

- Encoder
- Masked skip connection
- Decoder

Controllable CAD Generation

- Model Encoder
- Code-Tree Generator
- Model Generator

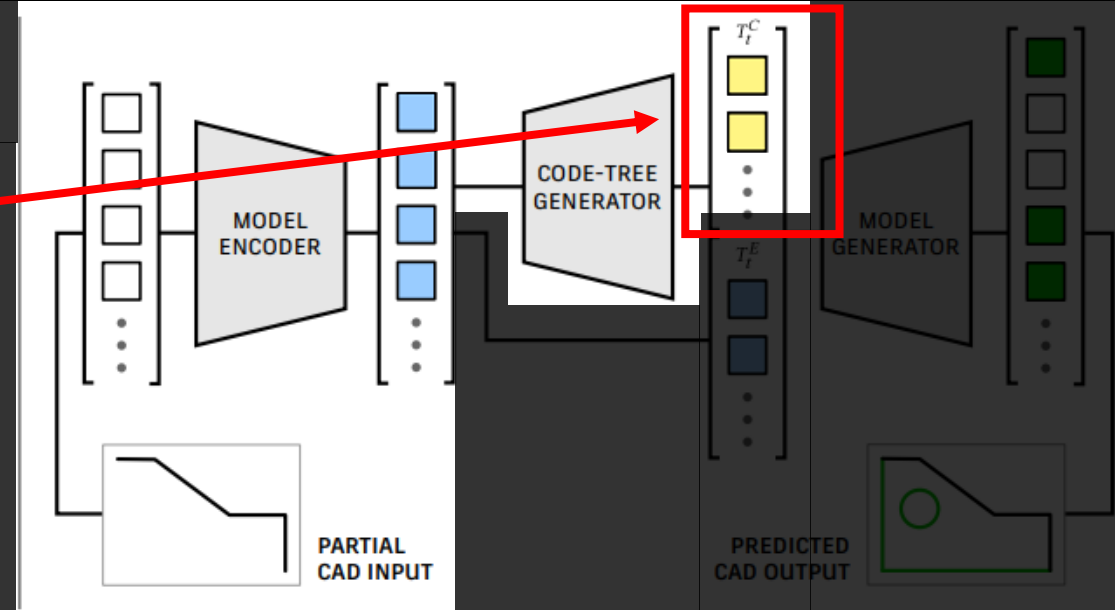
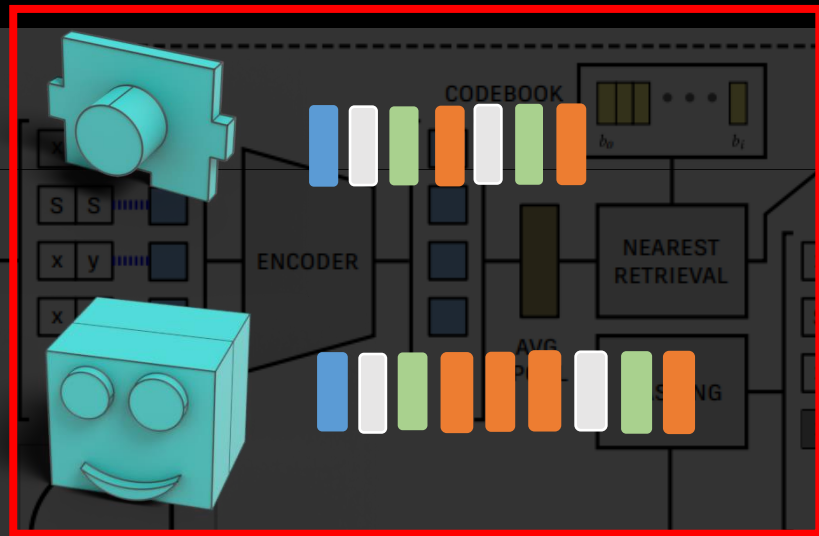

Three-Level Codebook Learning

- Encoder
- Masked skip connection
- Decoder

Controllable CAD Generation

- Model Encoder
- Code-Tree Generator
- Model Generator

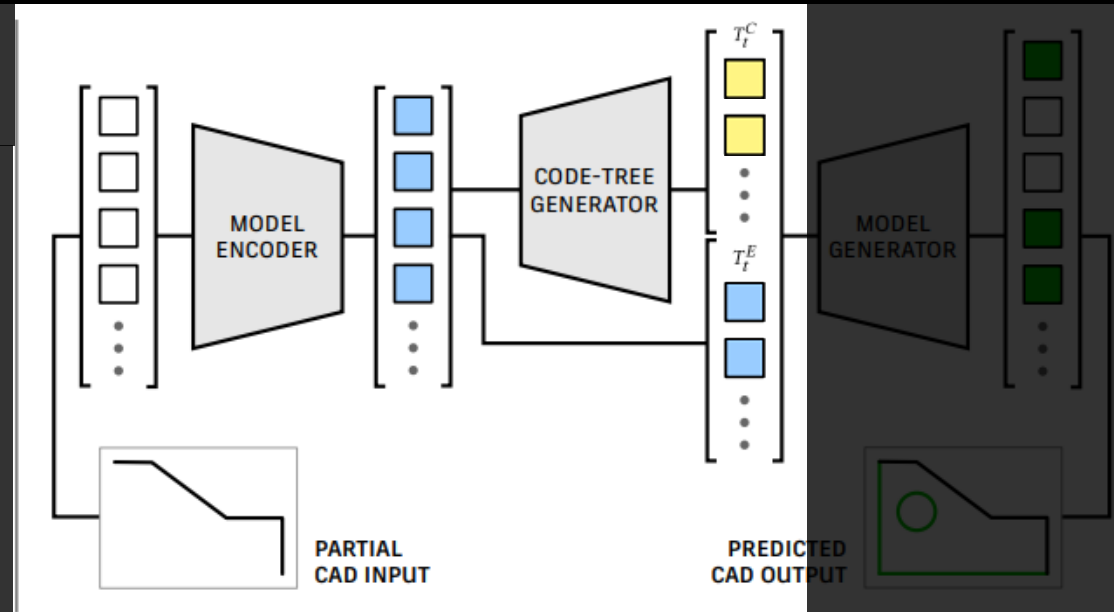
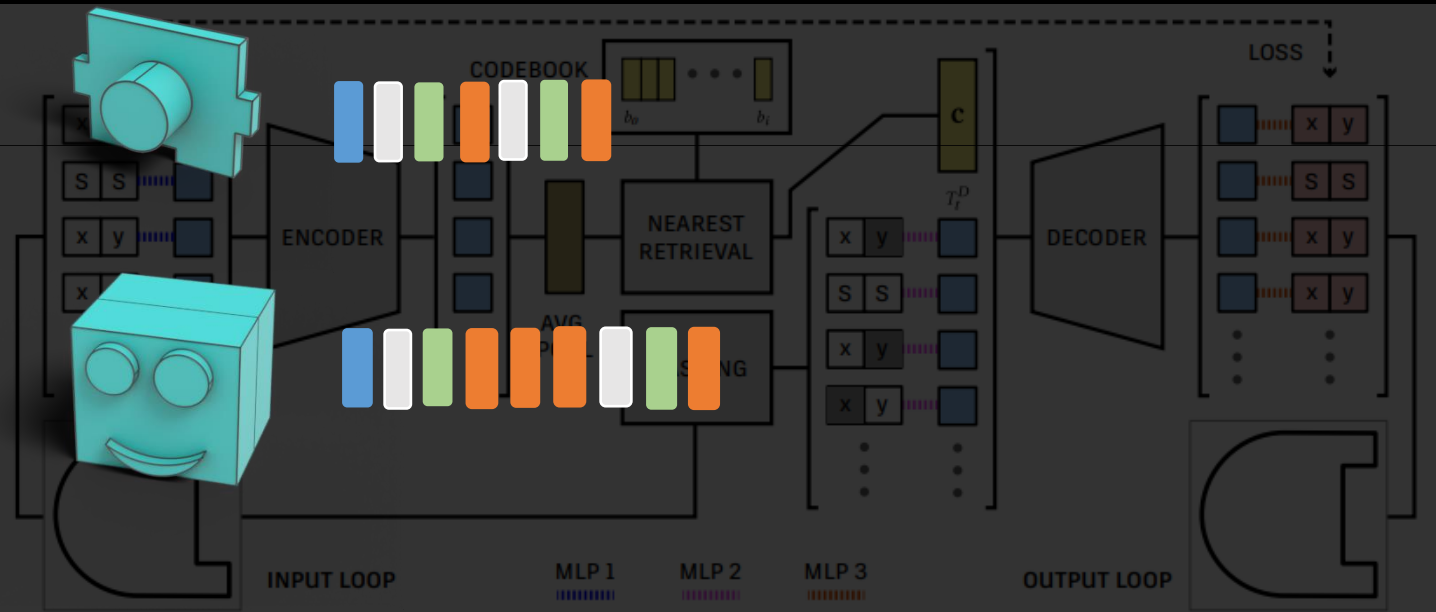

Three-Level Codebook Learning

- Encoder
- Masked skip connection
- Decoder

Controllable CAD Generation

- Model Encoder
- Code-Tree Generator
- Model Generator

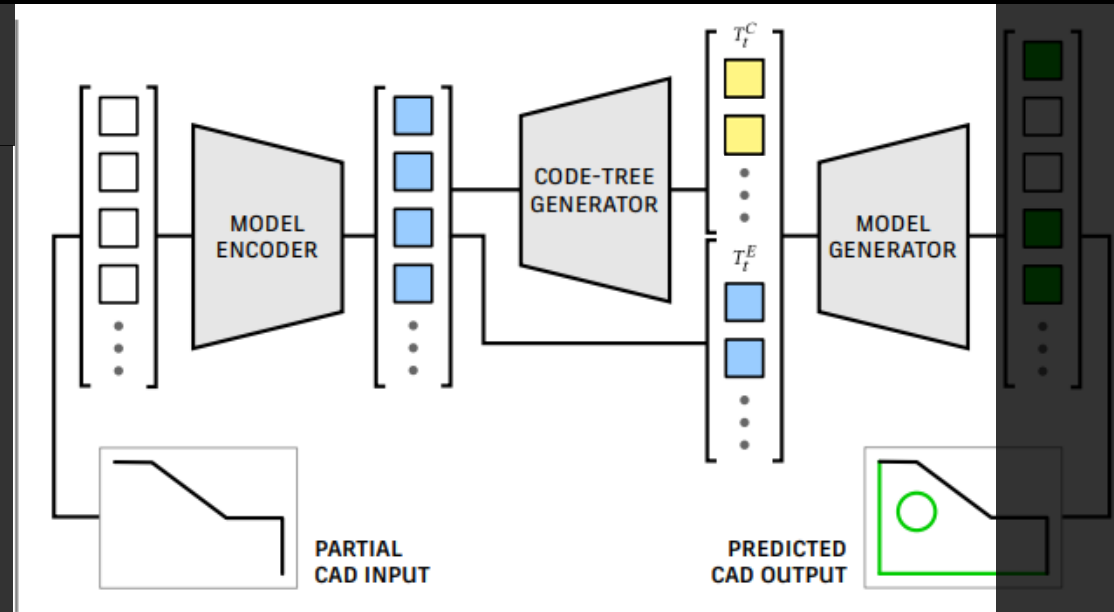
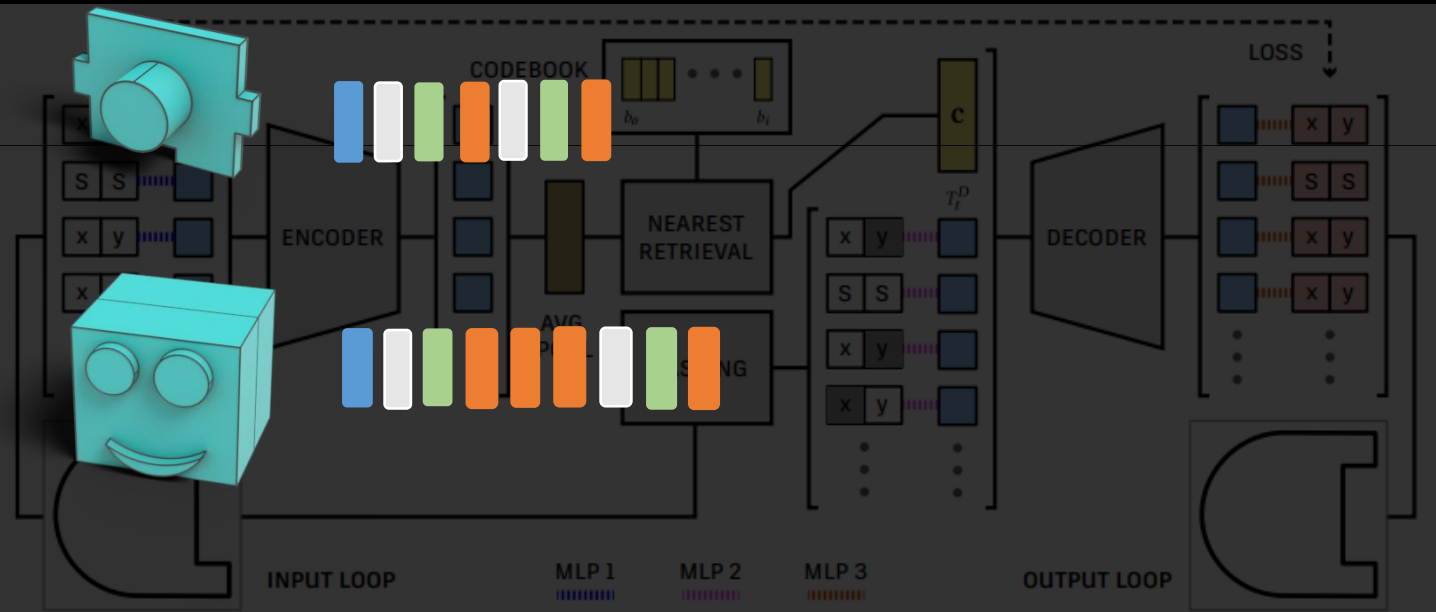

Three-Level Codebook Learning

- Encoder
- Masked skip connection
- Decoder

Controllable CAD Generation

- Model Encoder
- Code-Tree Generator
- Model Generator

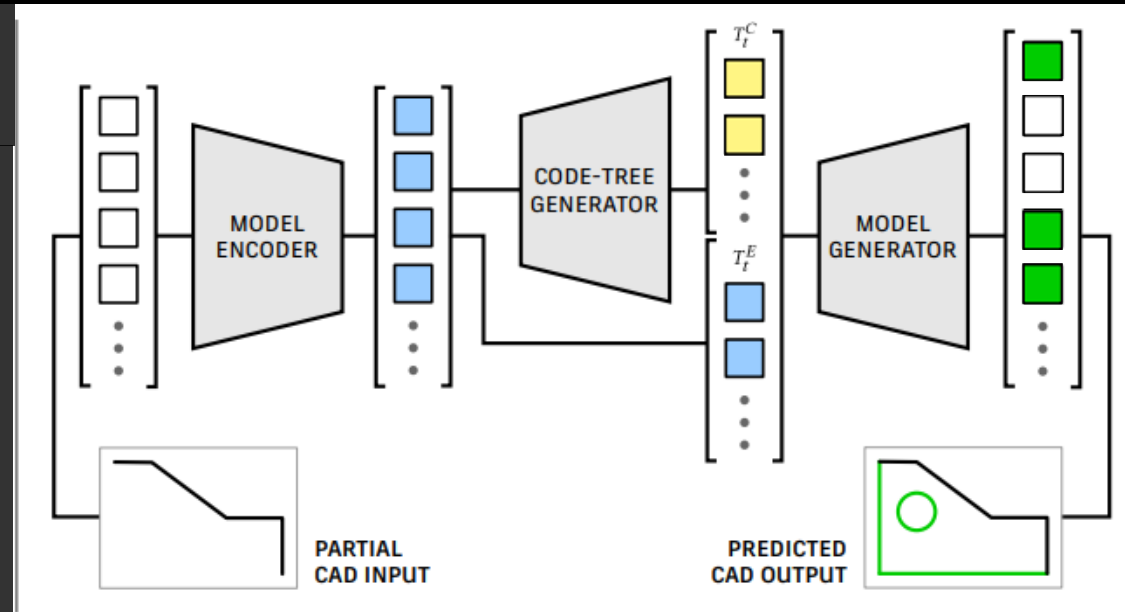
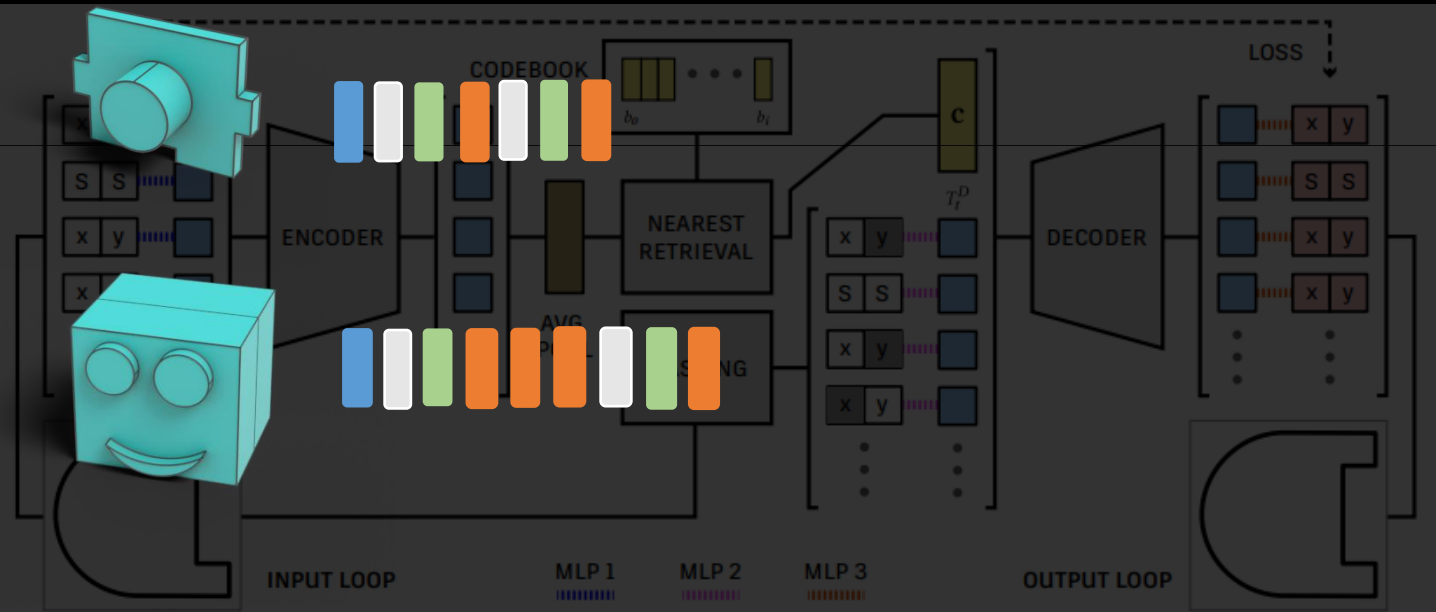

Three-Level Codebook Learning

- Encoder
- Masked skip connection
- Decoder

Controllable CAD Generation

- Model Encoder
- Code-Tree Generator
- Model Generator

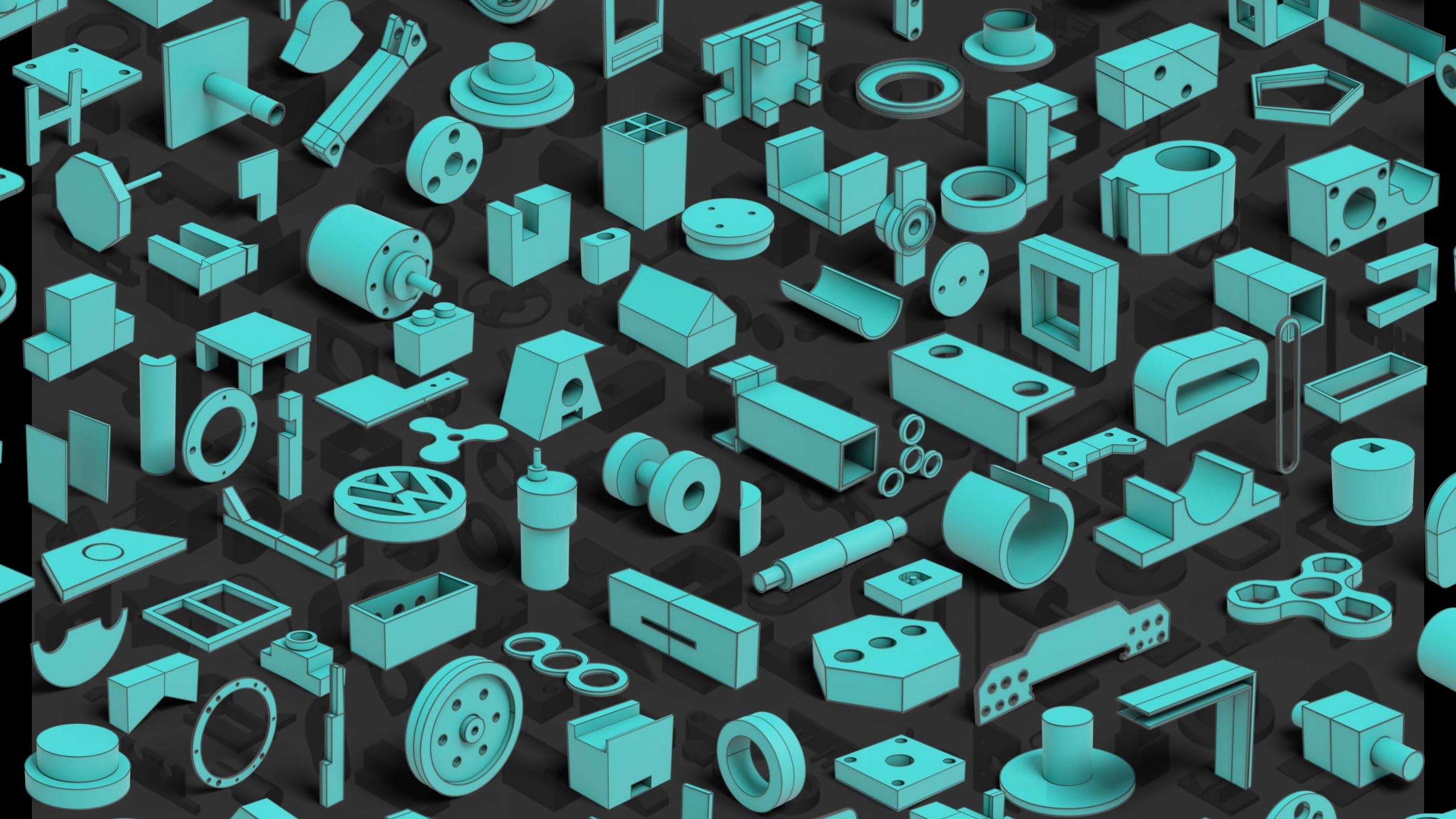

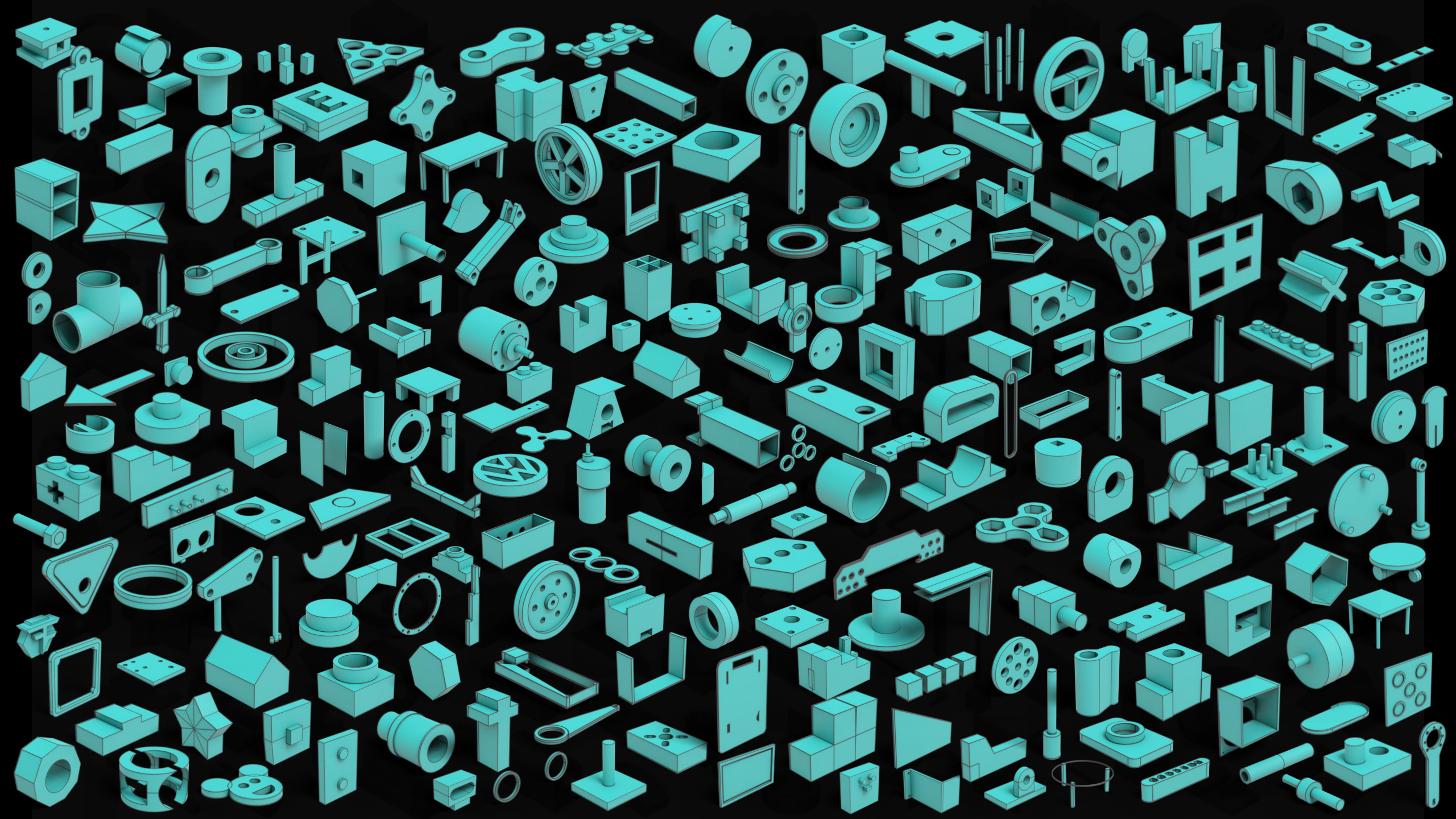

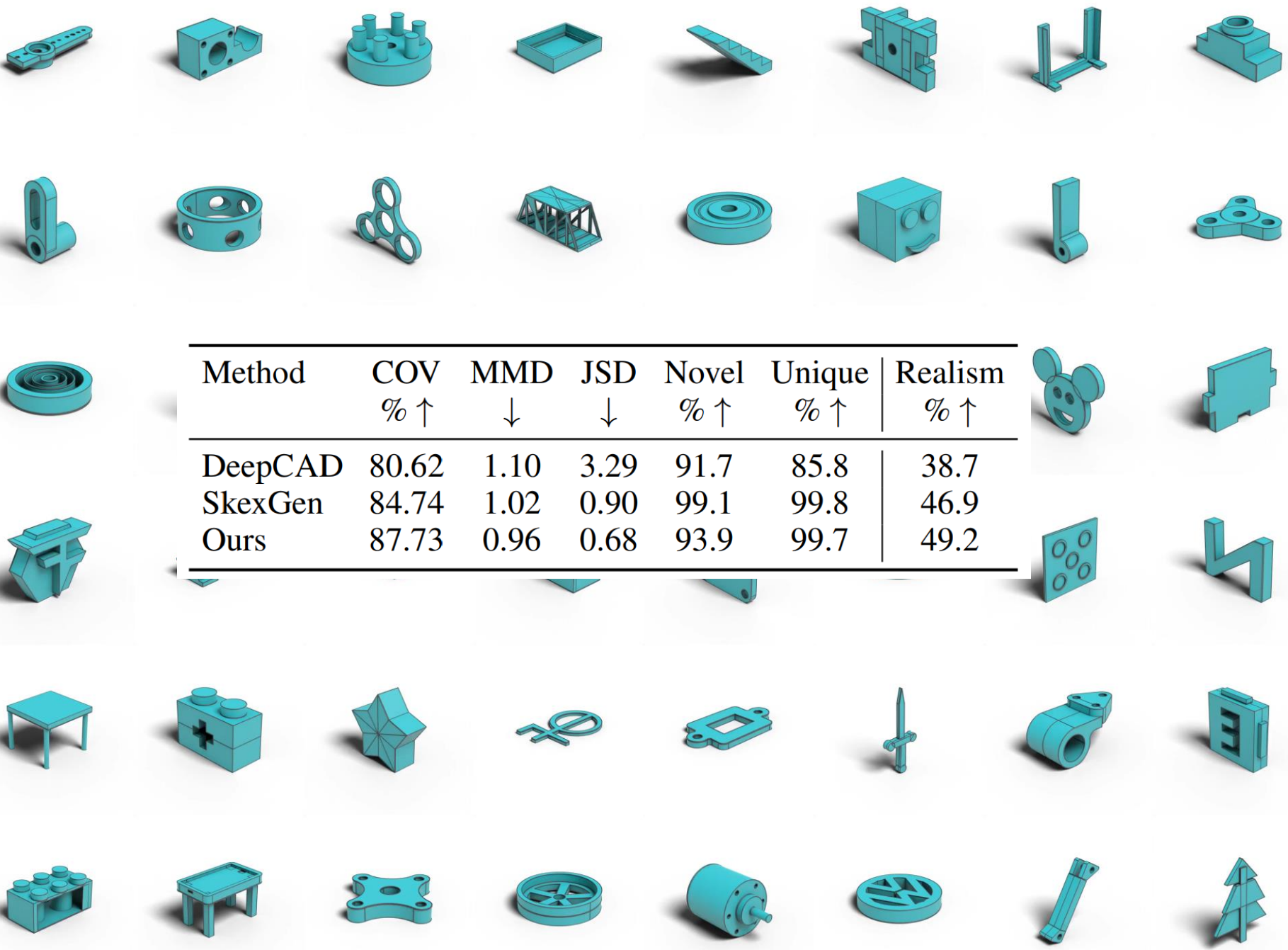

Method	COV % ↑	MMD ↓	JSD ↓	Novel % ↑	Unique % ↑	Realism % ↑
DeepCAD	80.62	1.10	3.29	91.7	85.8	38.7
SkexGen	84.74	1.02	0.90	99.1	99.8	46.9
Ours	87.73	0.96	0.68	93.9	99.7	49.2

Code Tree Editing

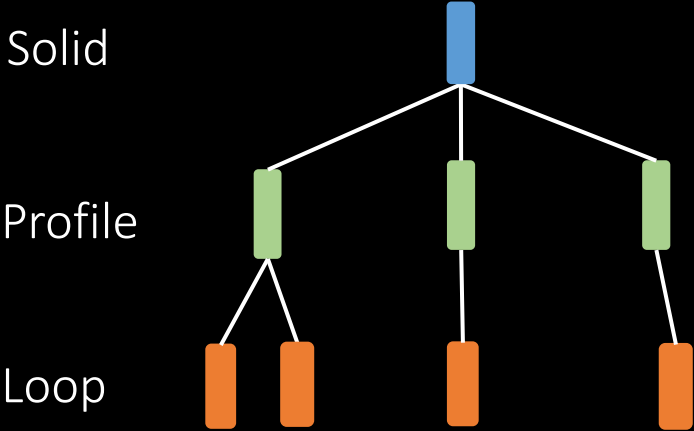

Code Tree Editing

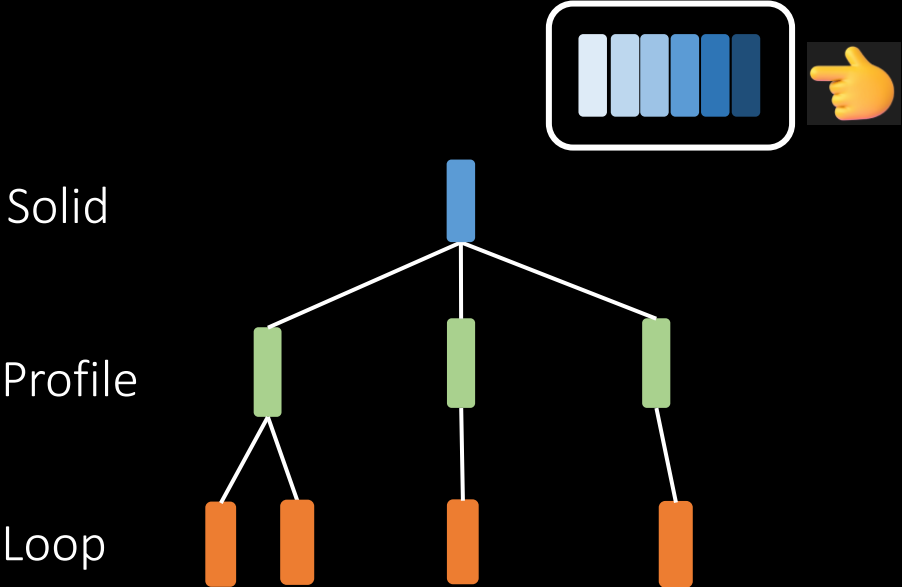

Code Tree Editing

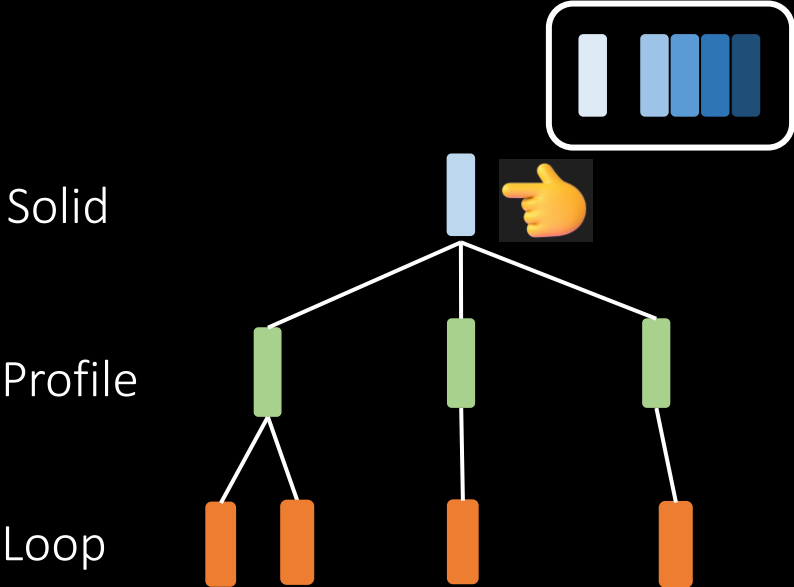

Code Tree Editing

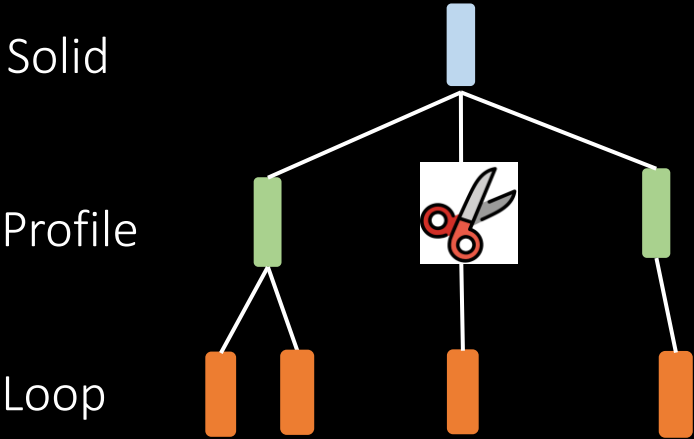

Code Tree Editing

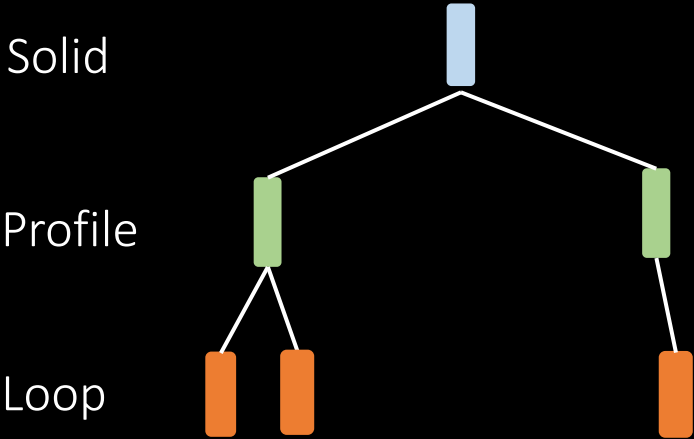

Code Tree Editing

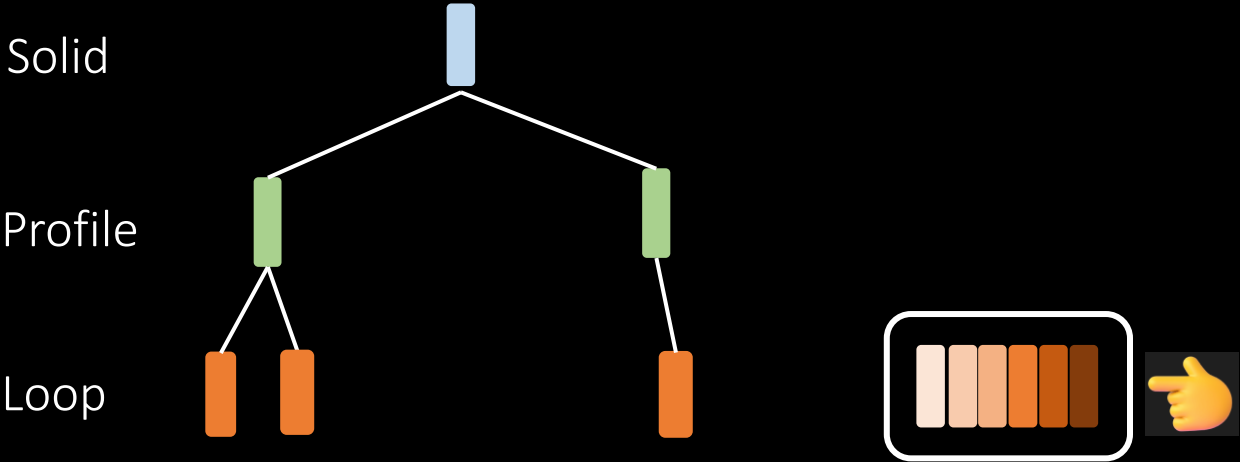

Code Tree Editing

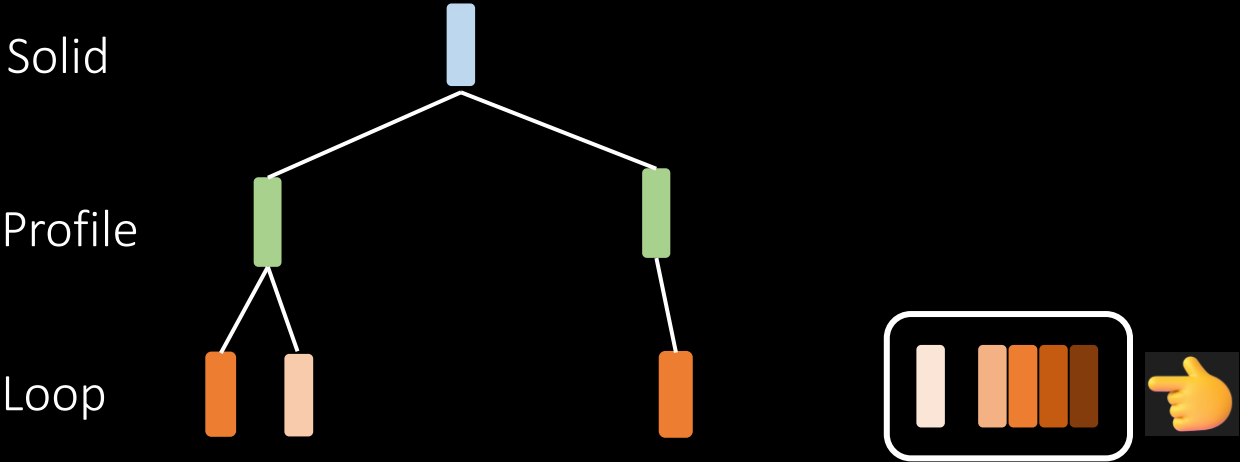

Code Tree Editing

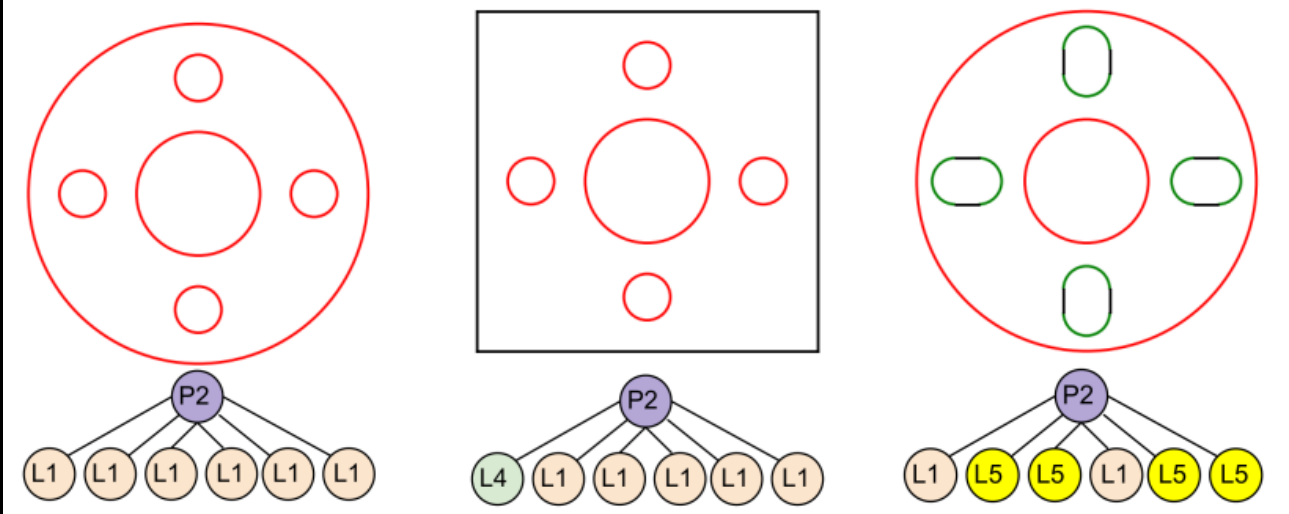
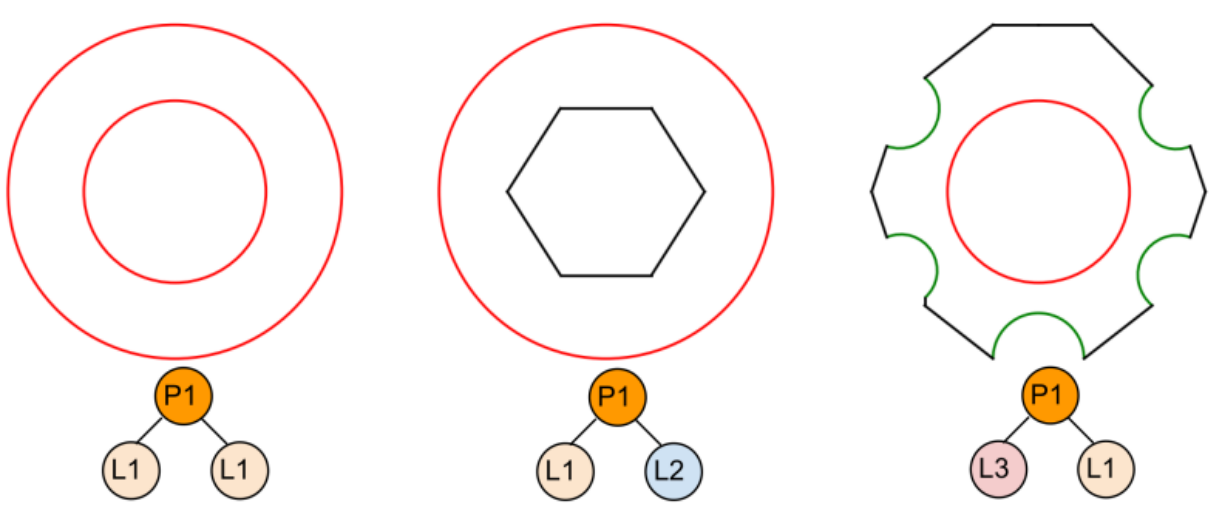

Code Tree Editing

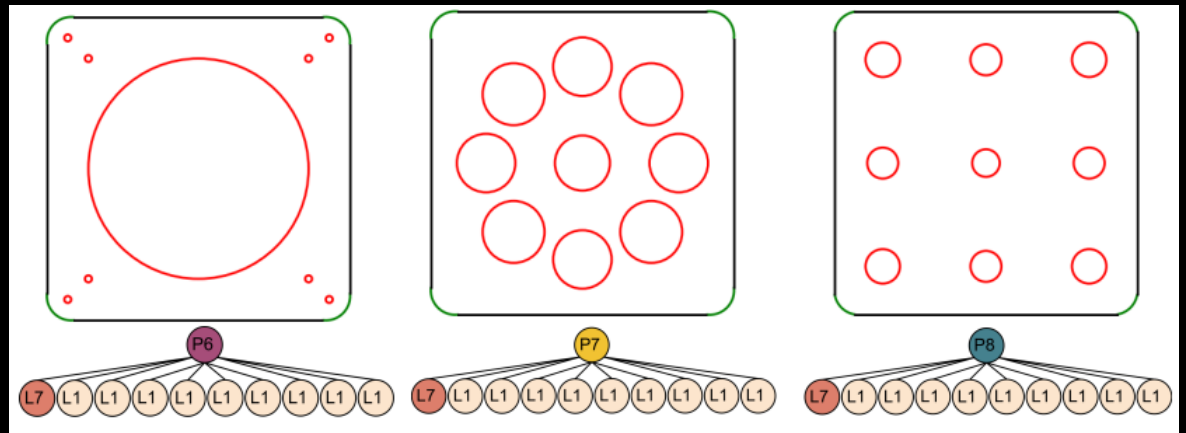
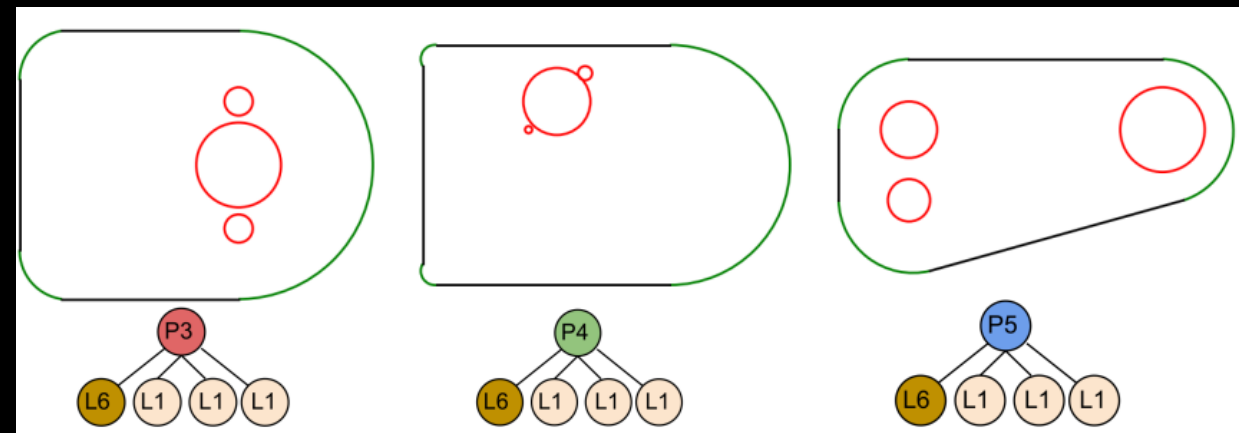
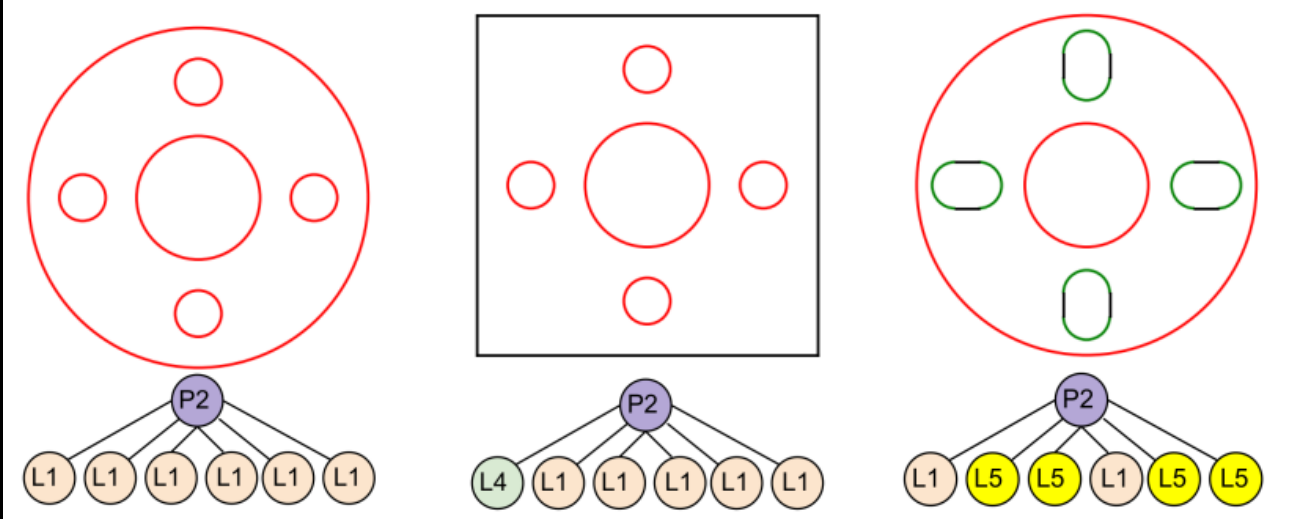
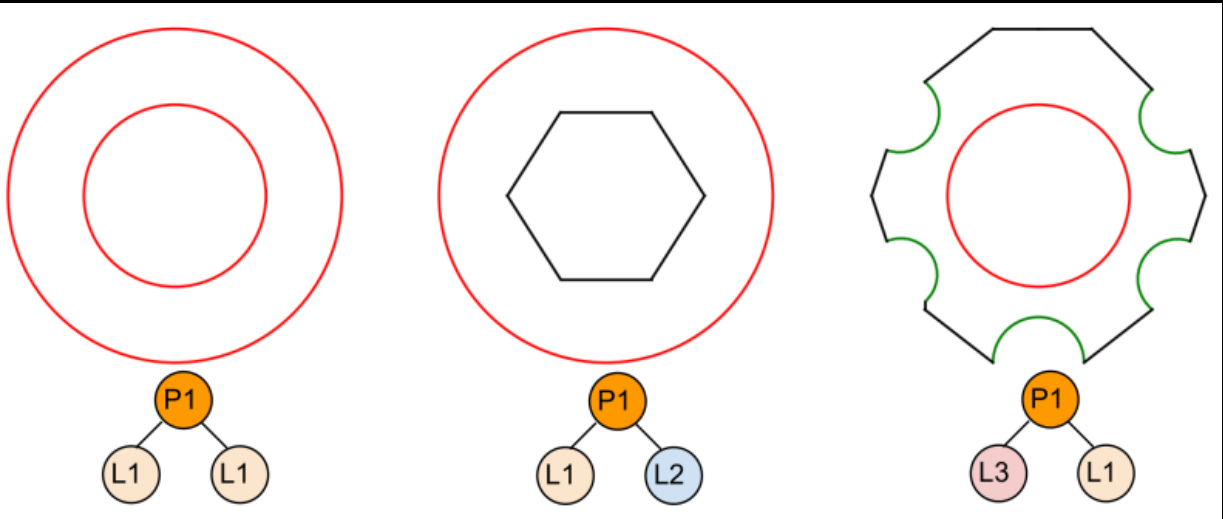

Code Tree Editing

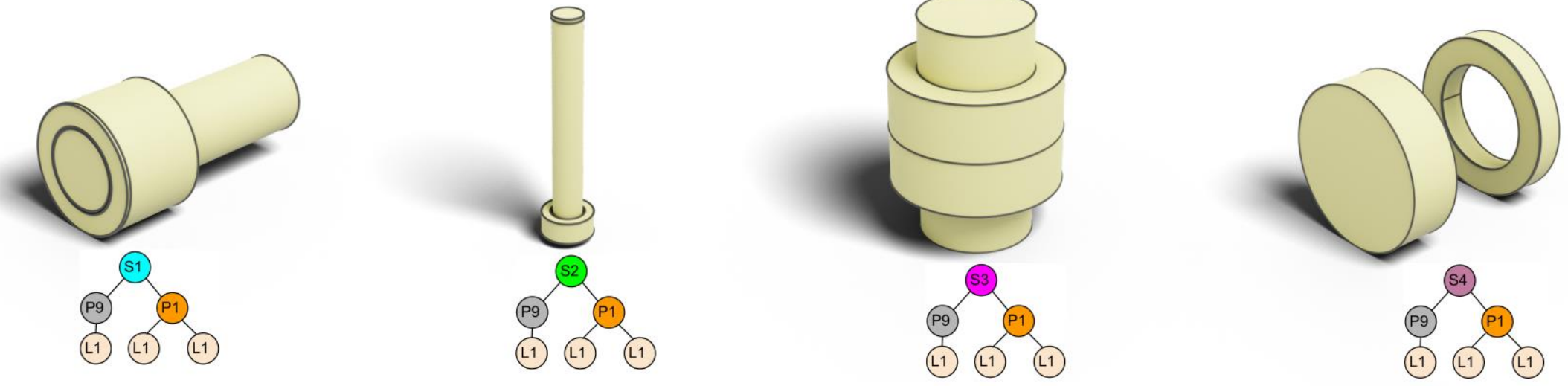
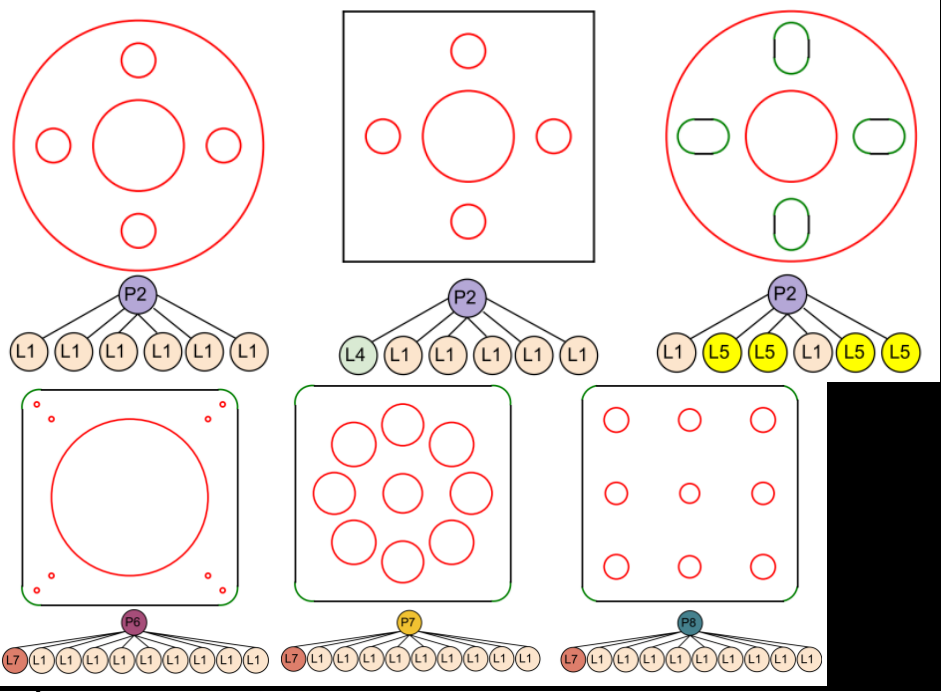
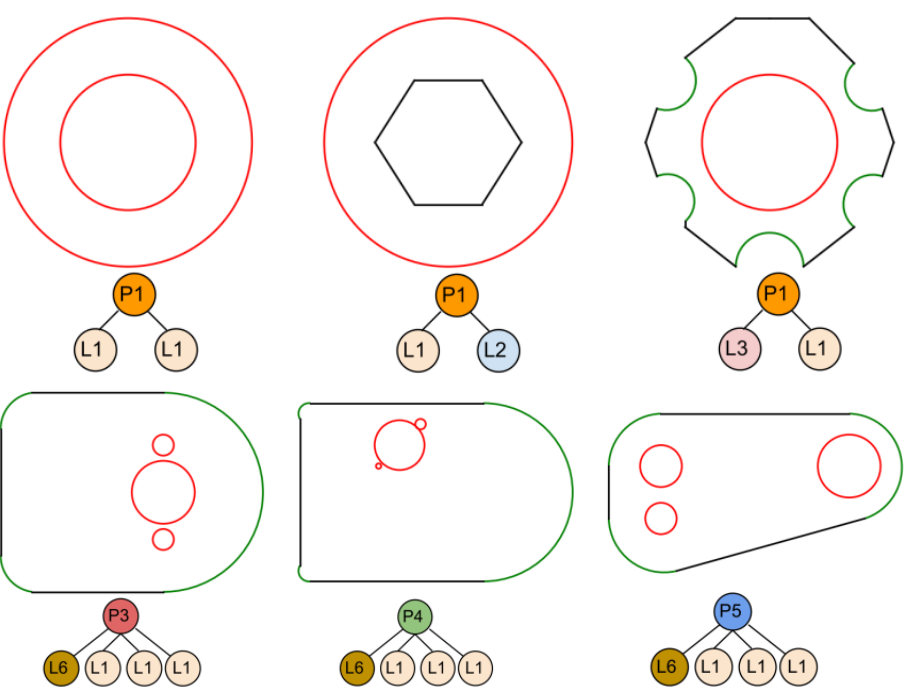

Design-Preserving Editing

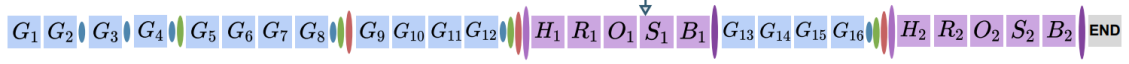
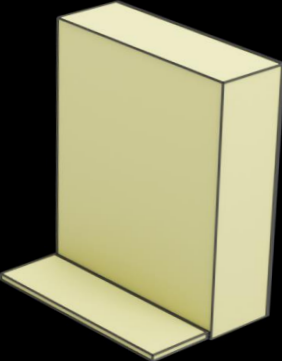

Design-Preserving Editing

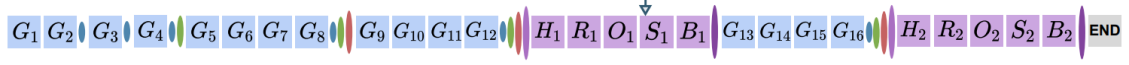
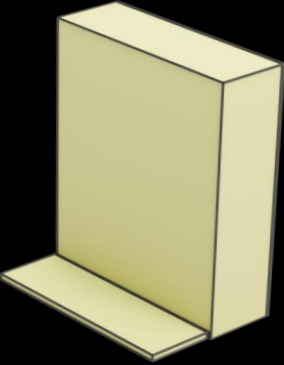
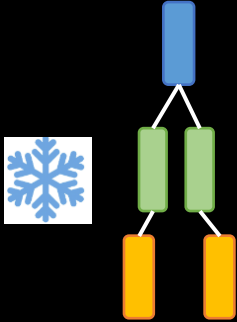

Design-Preserving Editing

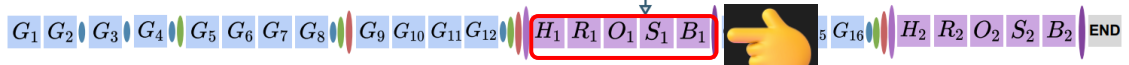
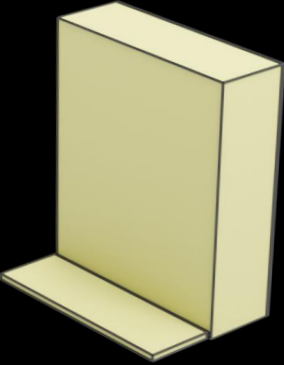
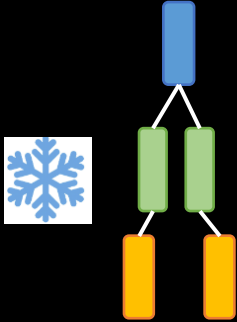

Design-Preserving Editing

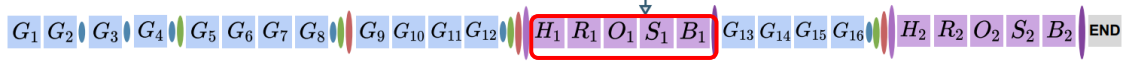
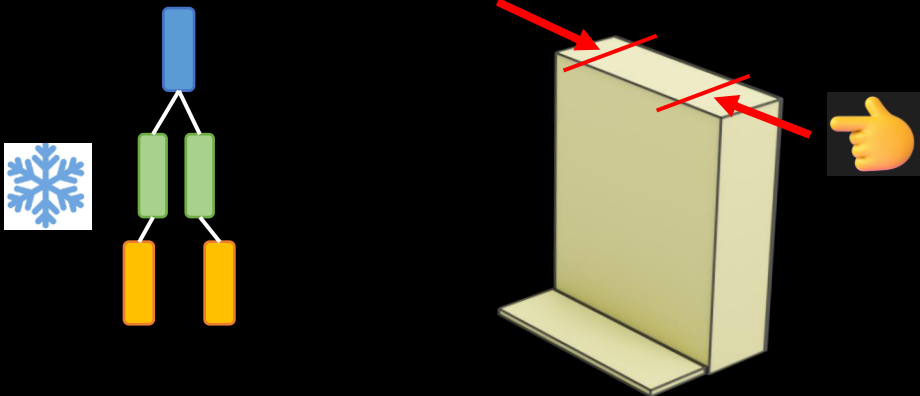

Design-Preserving Editing

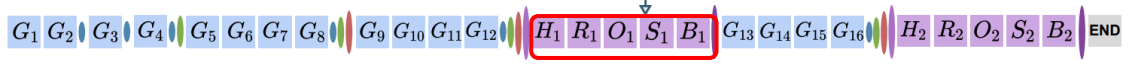
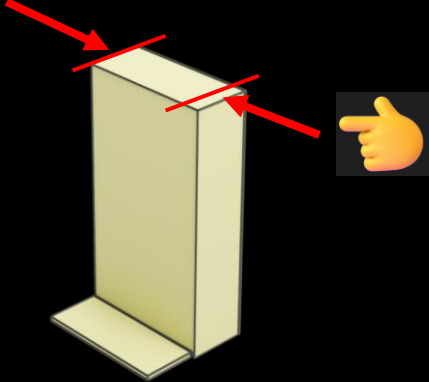
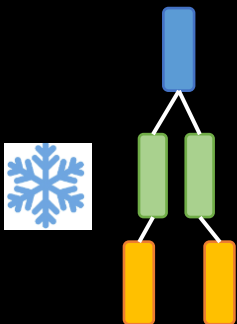

Design-Preserving Editing

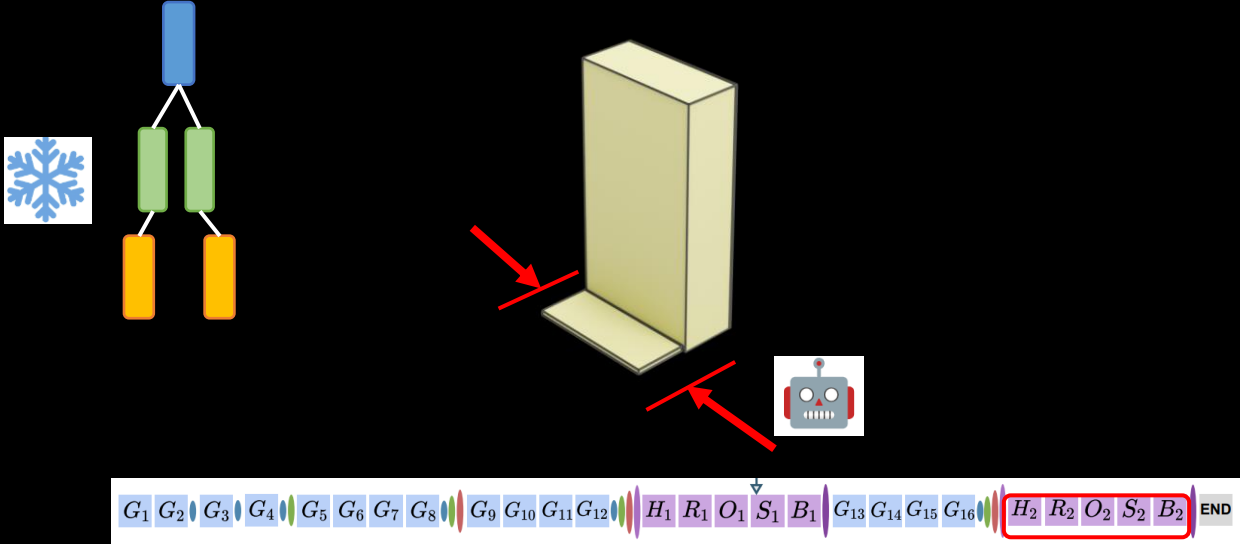

Design-Preserving Editing

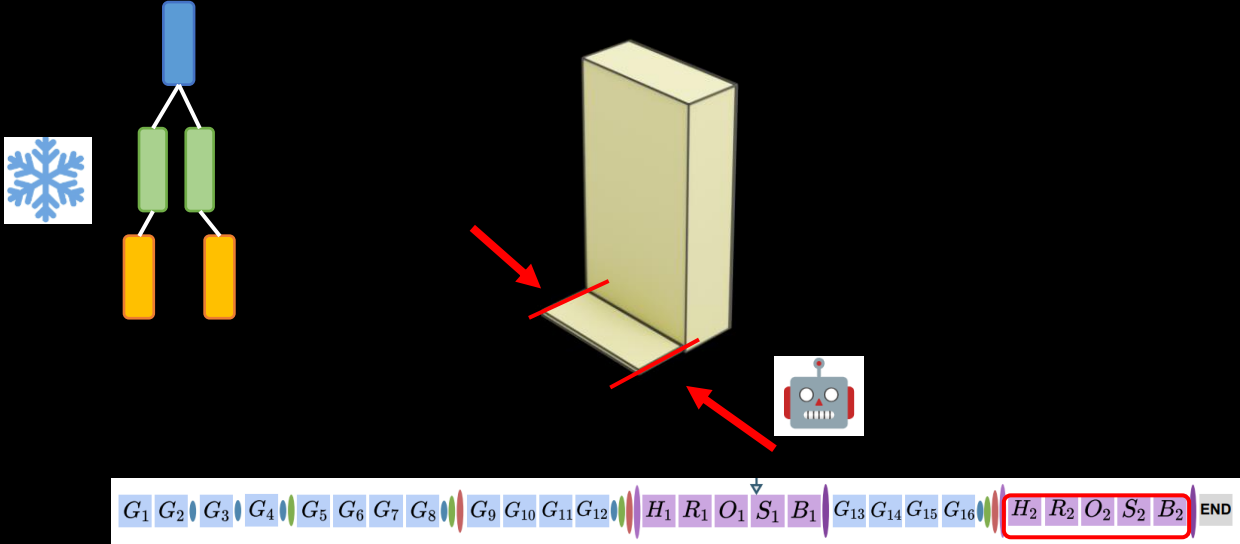

Autocomplete from Partial 2D Loops

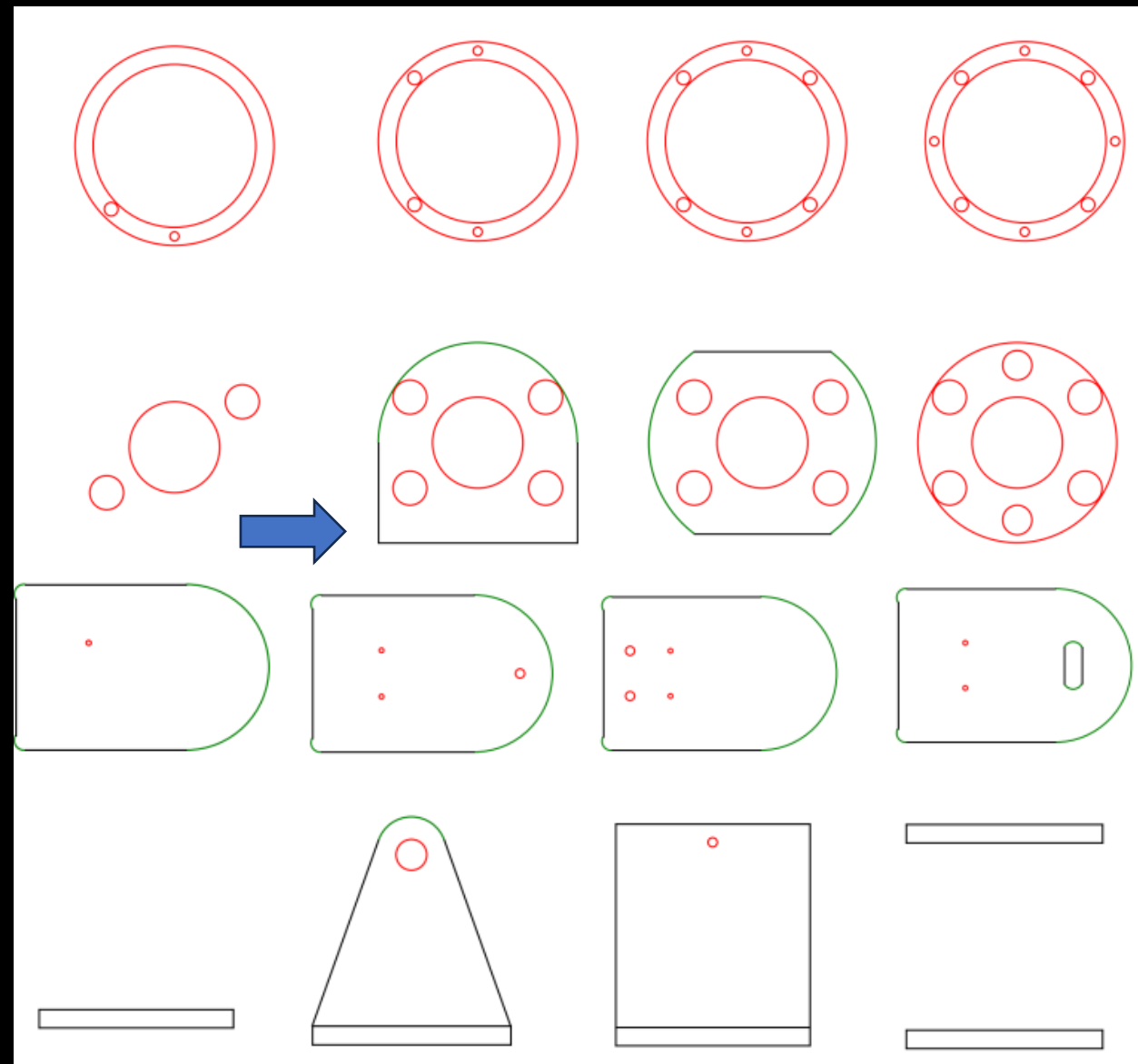
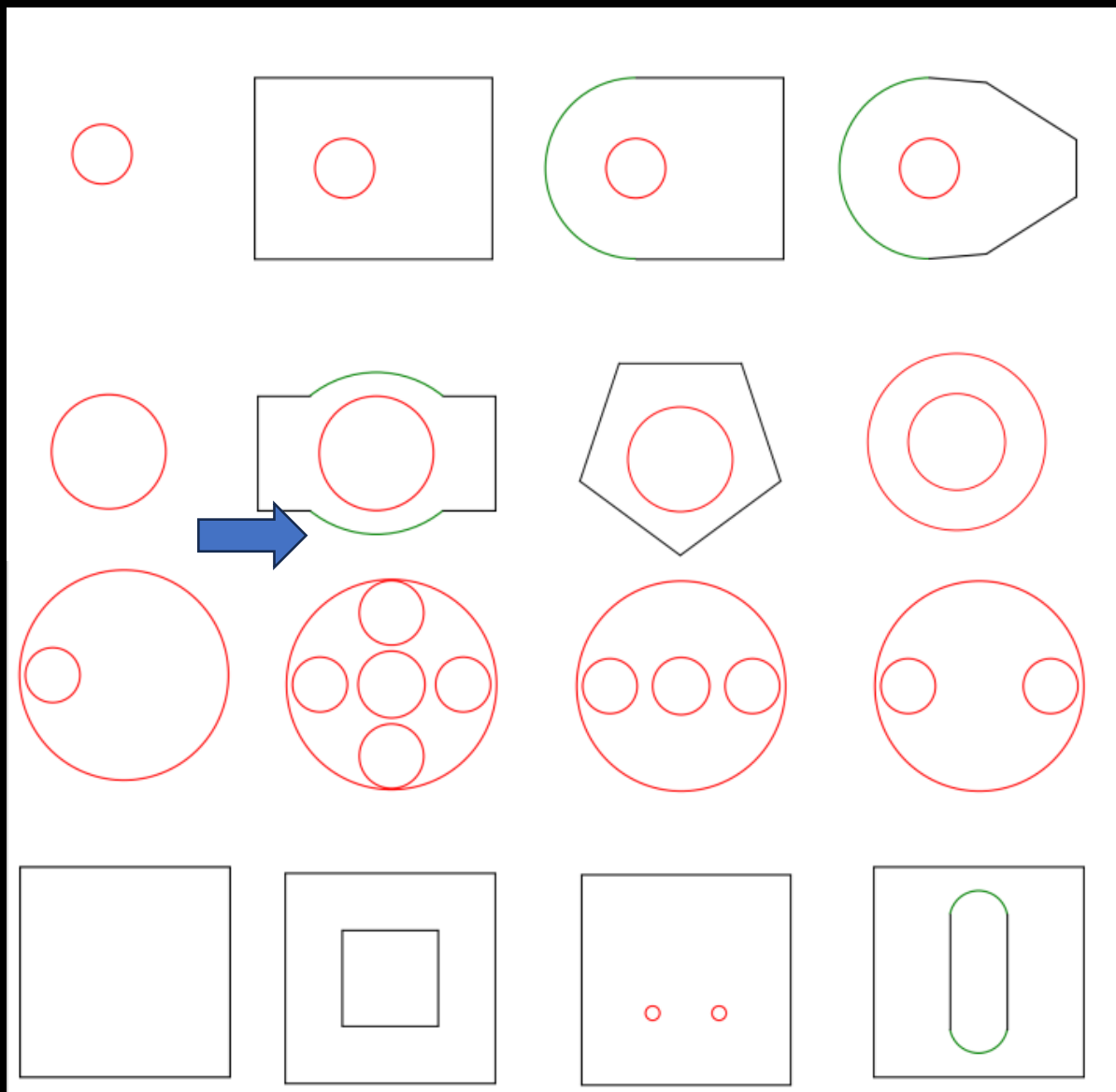

Autocomplete from Partial Extruded Profiles

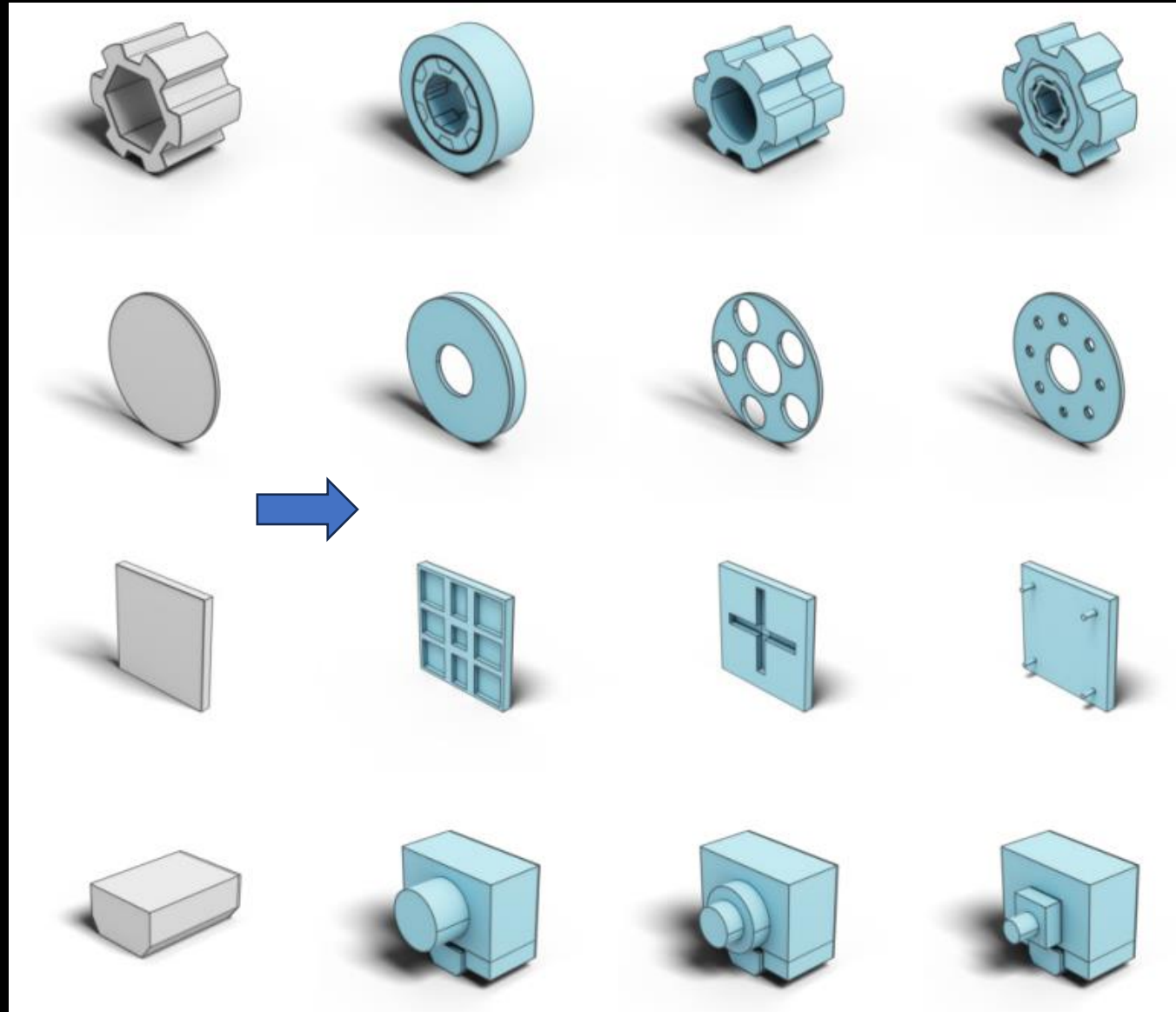

Instance-Agnostic Design Pattern

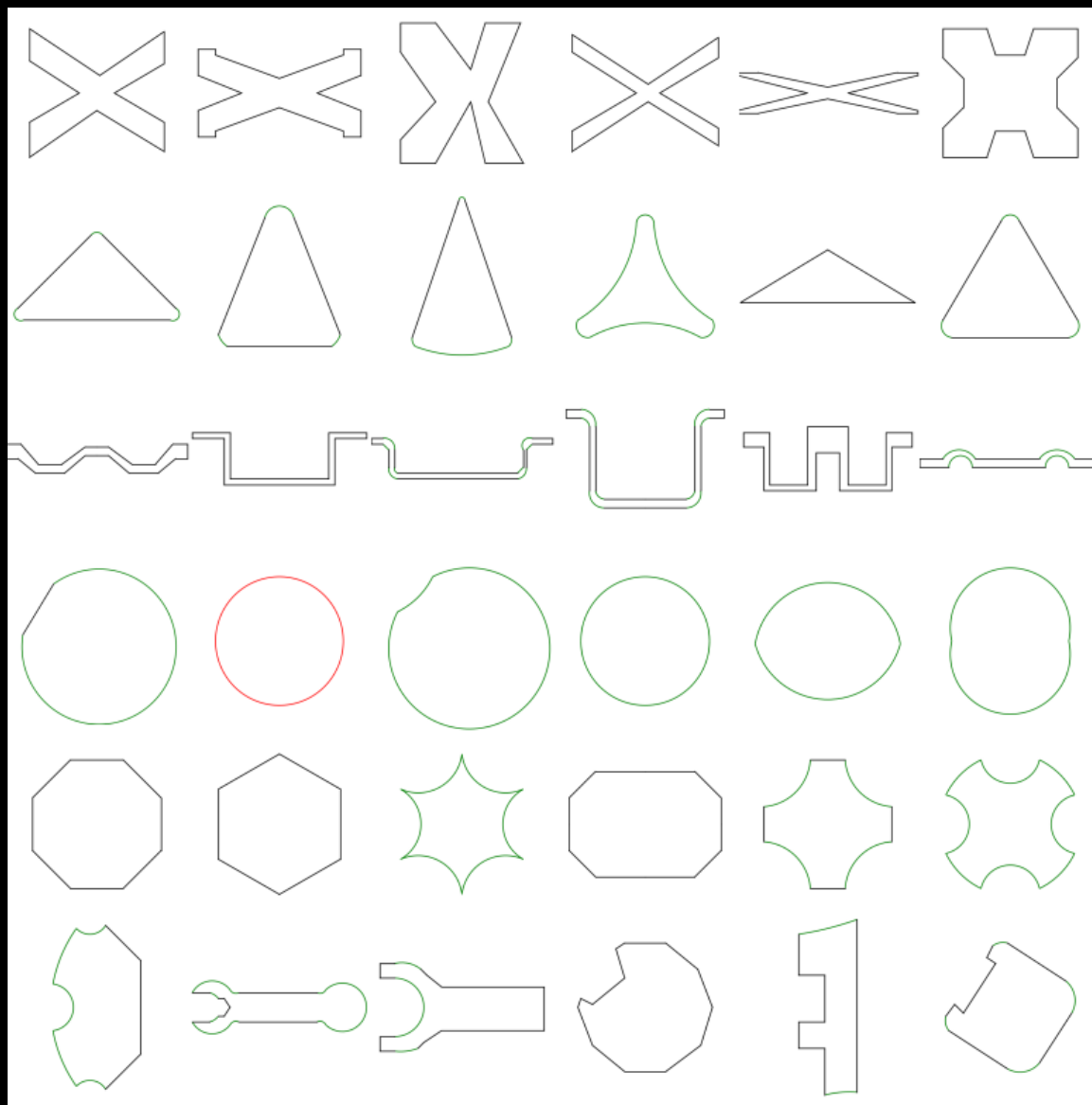

Loop Codebook: each row mapped to the same code

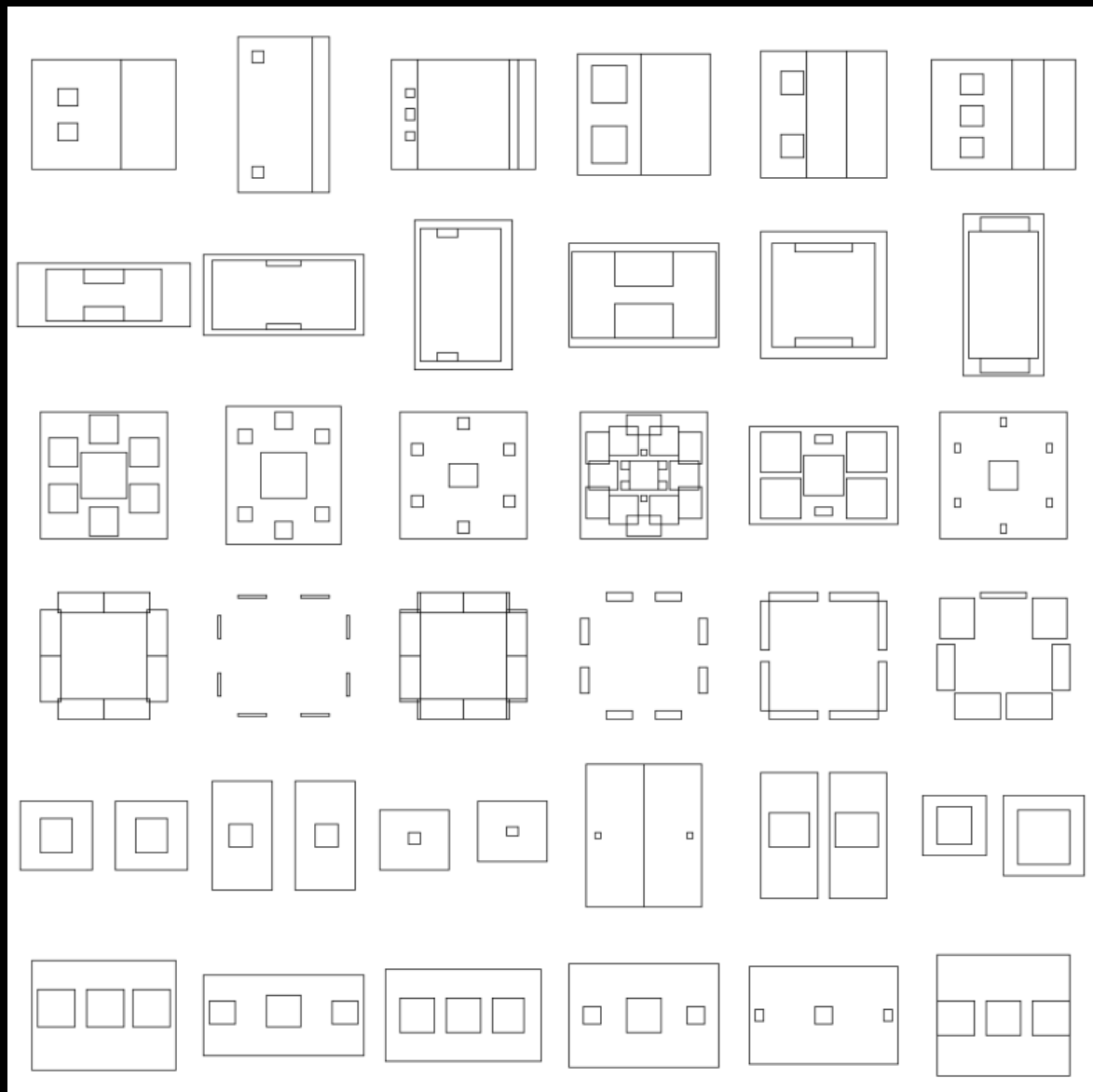

Profile Codebook: each row mapped to the same code

Hierarchical Neural Coding for Controllable CAD Model Generation



Project Website: <https://hnc-cad.github.io/>



This research is partially supported by NSERC Discovery Grants with Accelerator Supplements and DND/NSERC Discovery Grant Supplement, NSERC Alliance Grants, and John R. Evans Leaders Fund (JELF)