

# MonoNeRF: Learning Generalizable NeRFs from Monocular Videos without Camera Poses

Yang Fu<sup>1</sup>, Ishan Misra<sup>2</sup>, Xiaolong Wang<sup>1</sup>

<sup>1</sup>UC San Diego, <sup>2</sup>FAIR Meta AI

# ~~Per-scene Optimization~~

## Generalizable NeRFs



NeRFs have achieved promising progress on rendering photorealistic images

# ~~Requirement on camera poses~~

Can we learn generalizable NeRFs without camera poses?

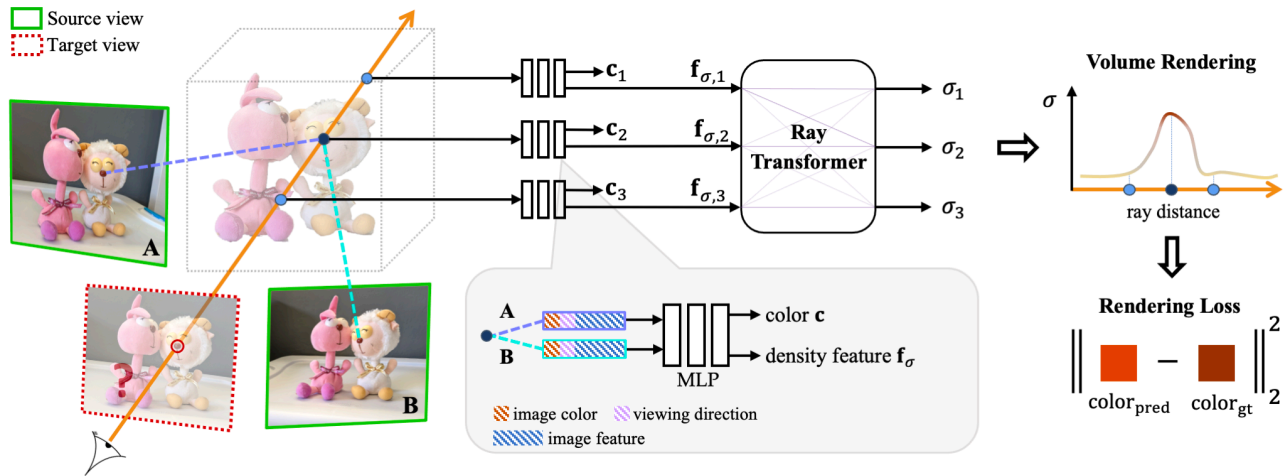

IBRNet



GPNR

Several efforts have been made on generalizable NeRFs

Monocular  
Depth



Input Video



Encoder

# Learn Generalizable NeRFs from Monocular Videos without Camera Poses

Multiplane NeRF Rendering

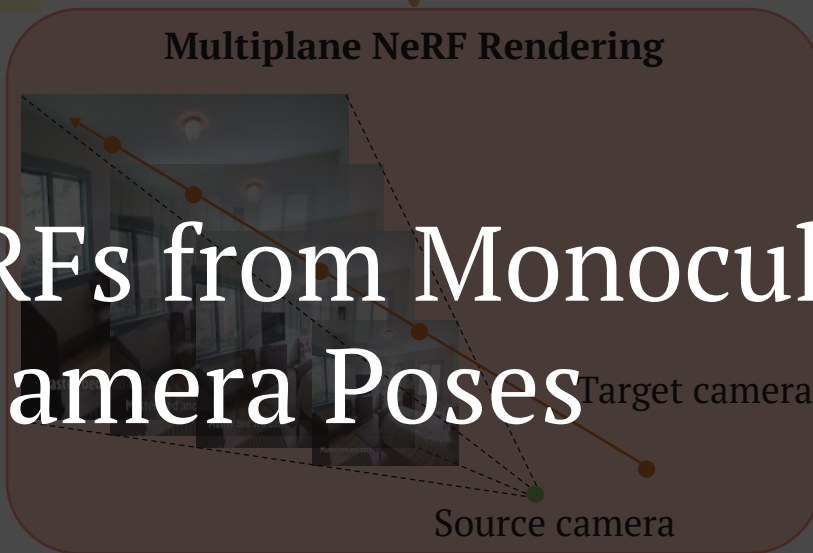

Novel View  
Reconstruction



Camera  
Trajectory

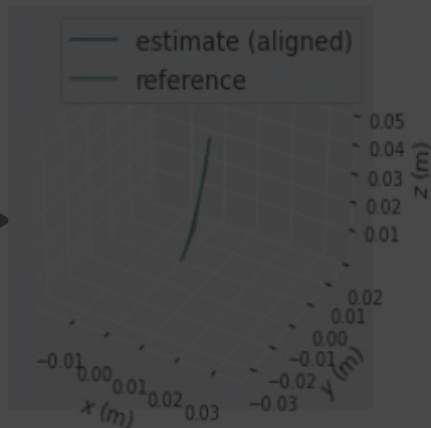

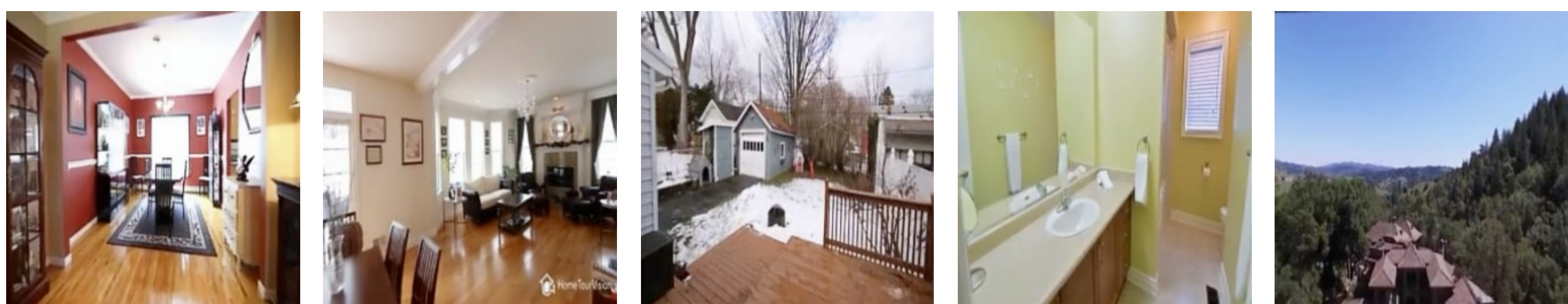

(a) Single-view Novel View Synthesis

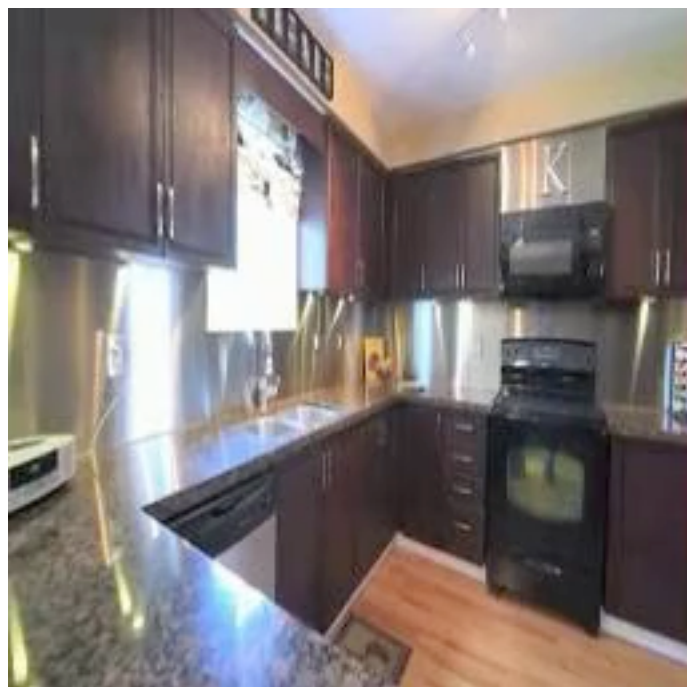

Input Video

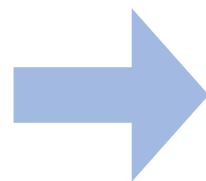

(b) Monocular Depth

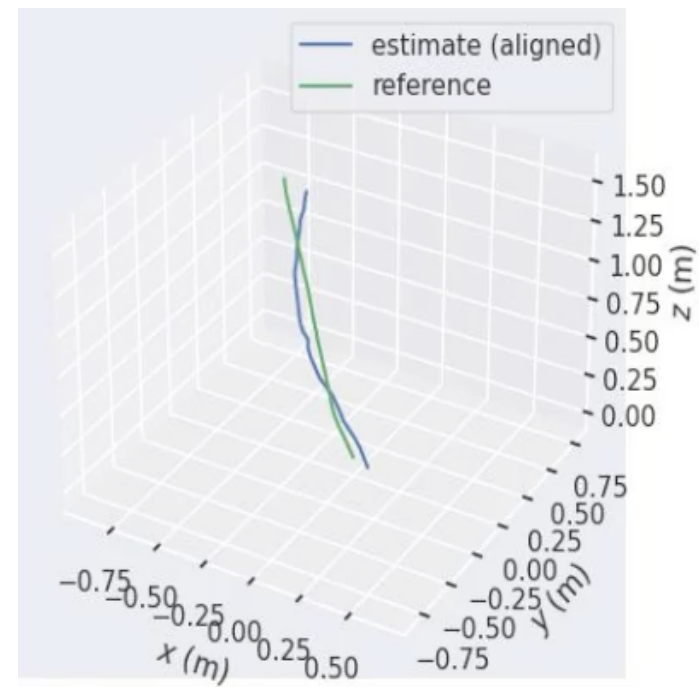

(c) Camera Trajectory

# Results

Novel View Synthesis

# Novel View Synthesis

**Input View**



**VideoAE**



**MonoNeRF**



# Novel View Synthesis

**Input View**



**VideoAE**



**MonoNeRF**





# Novel View Synthesis

**Input View**



**VideoAE**



**MonoNeRF**

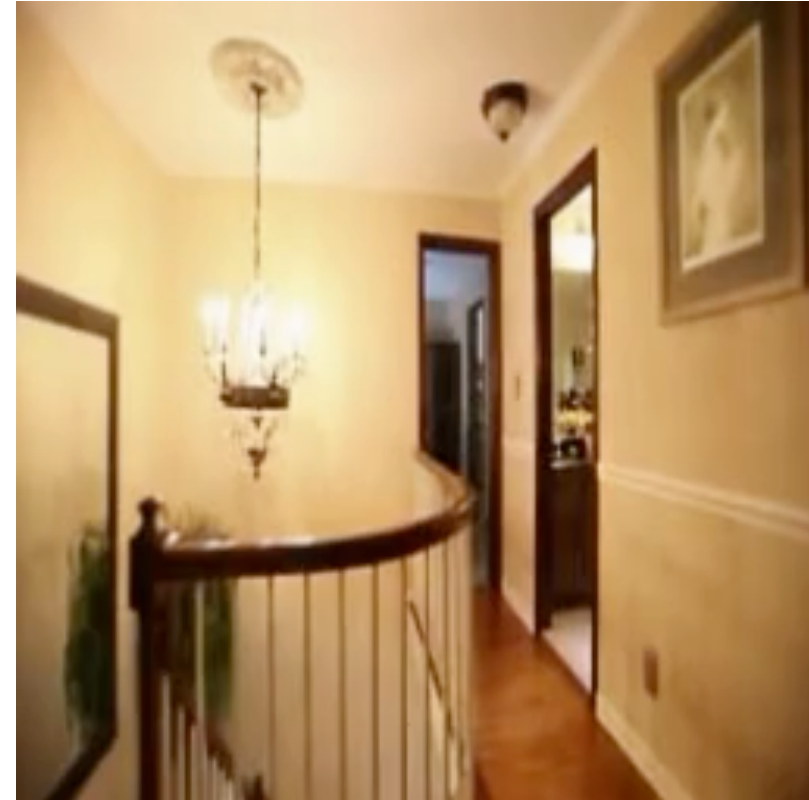

# Results

## Depth Estimation

# Depth Estimation

Input Video



Depth Estimation

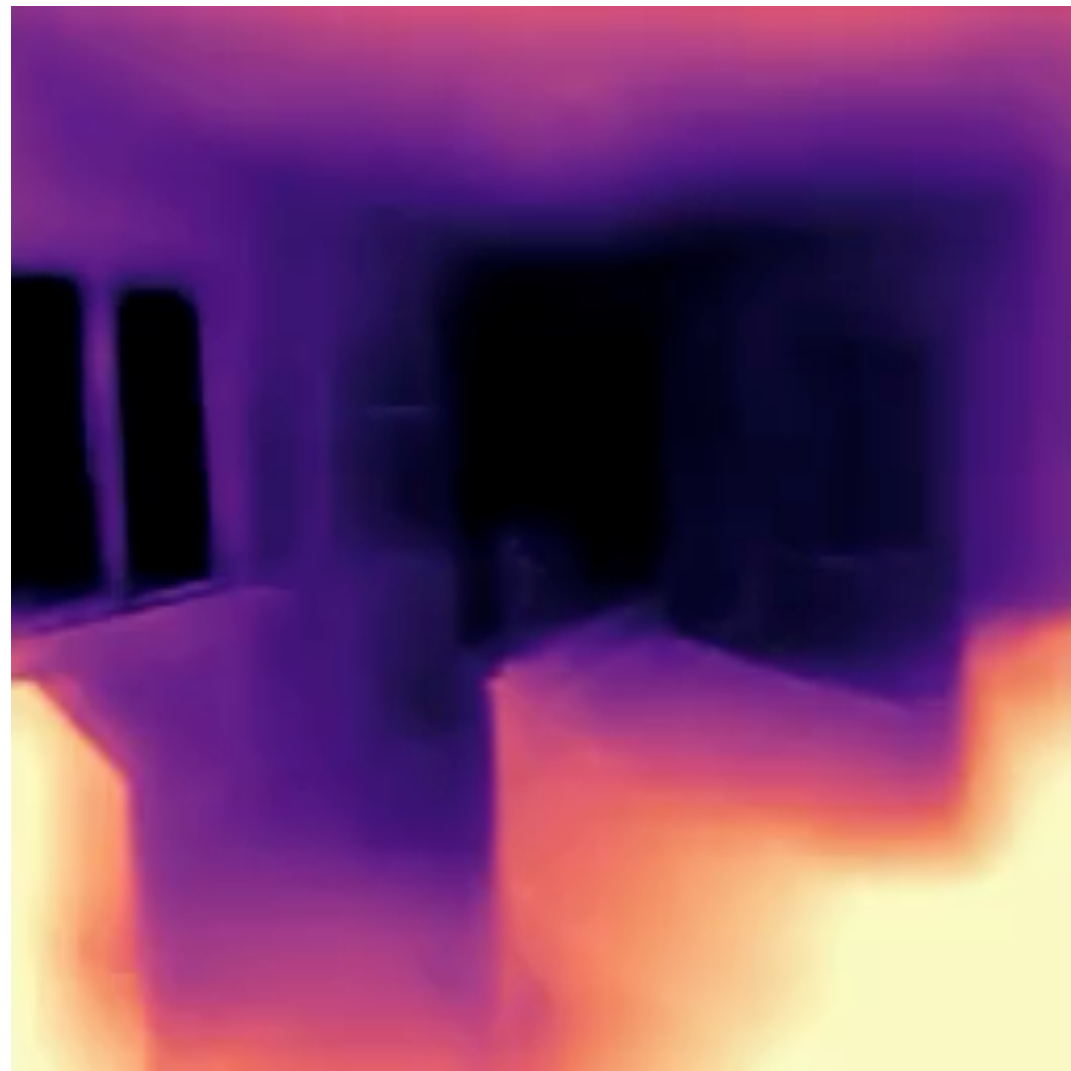

# Depth Estimation

**Input Video**



**Depth Estimation**

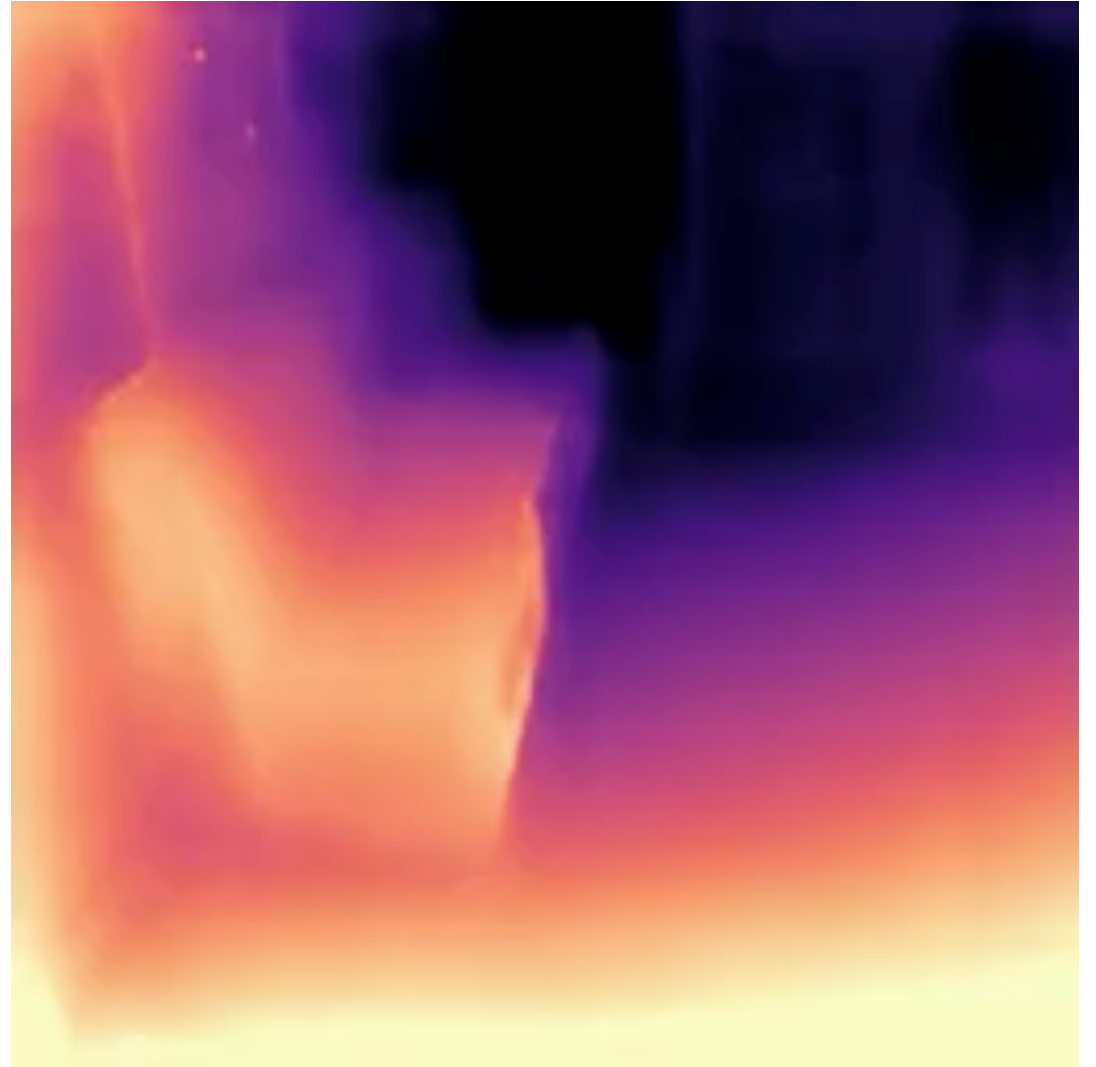

# Depth Estimation

Input Video



Depth Estimation

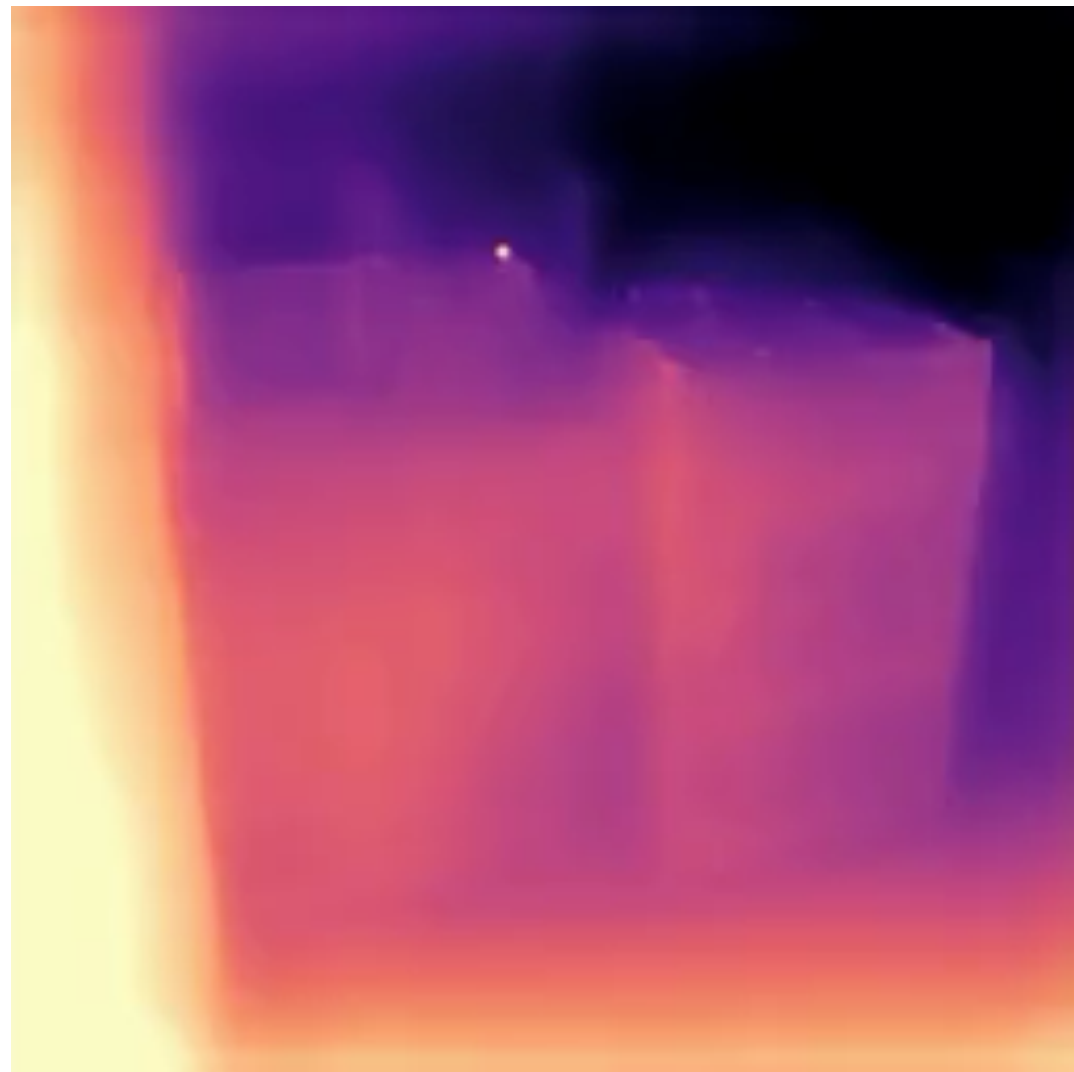

# Results

Camera Pose Estimation

# Camera Pose Estimation

Input Video



VideoAE

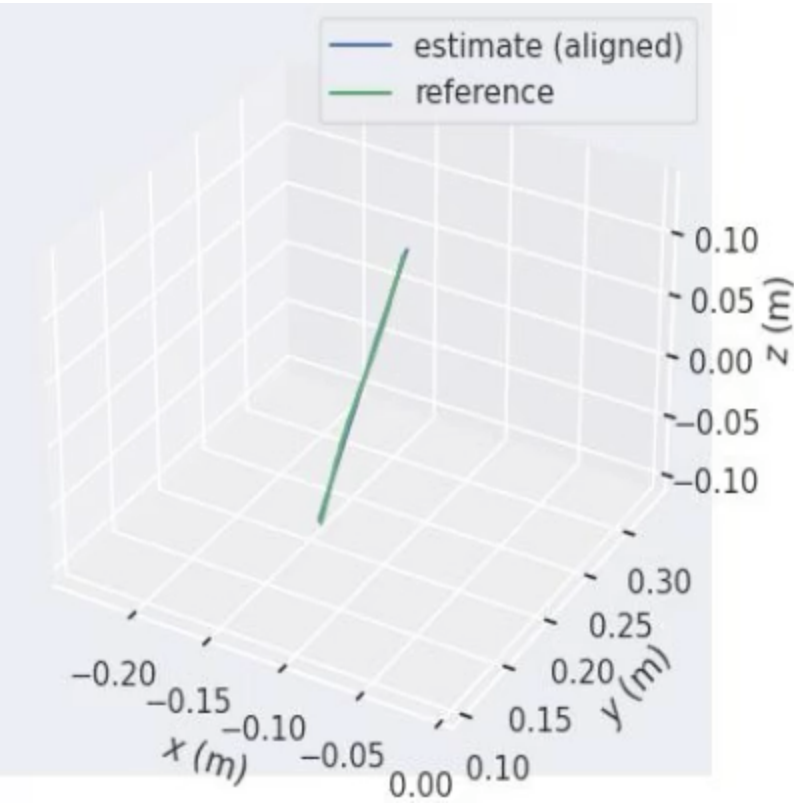

MonoNeRF

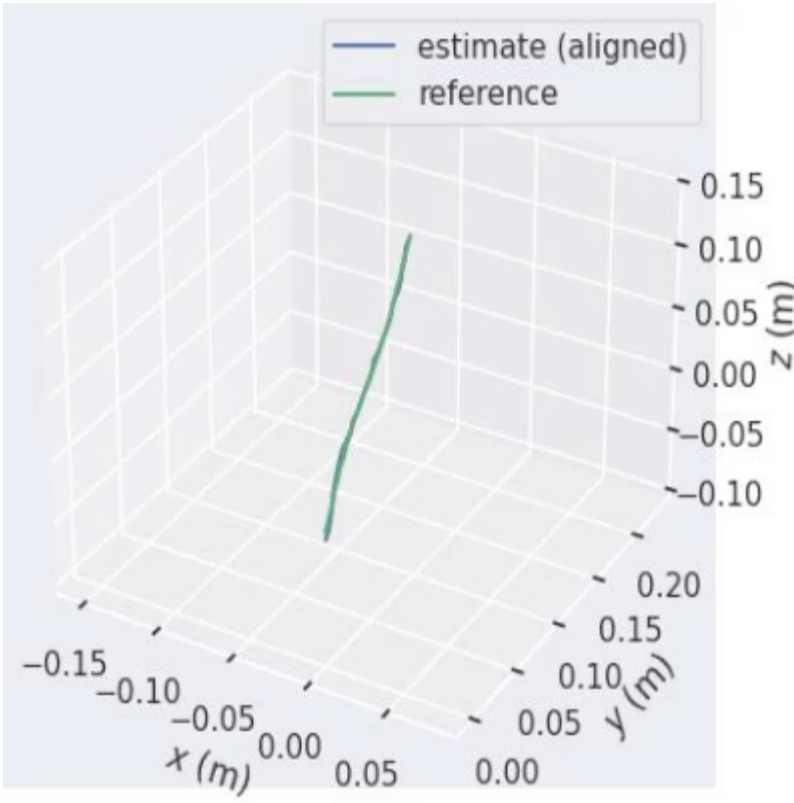

# Camera Pose Estimation

## Input Video



## VideoAE

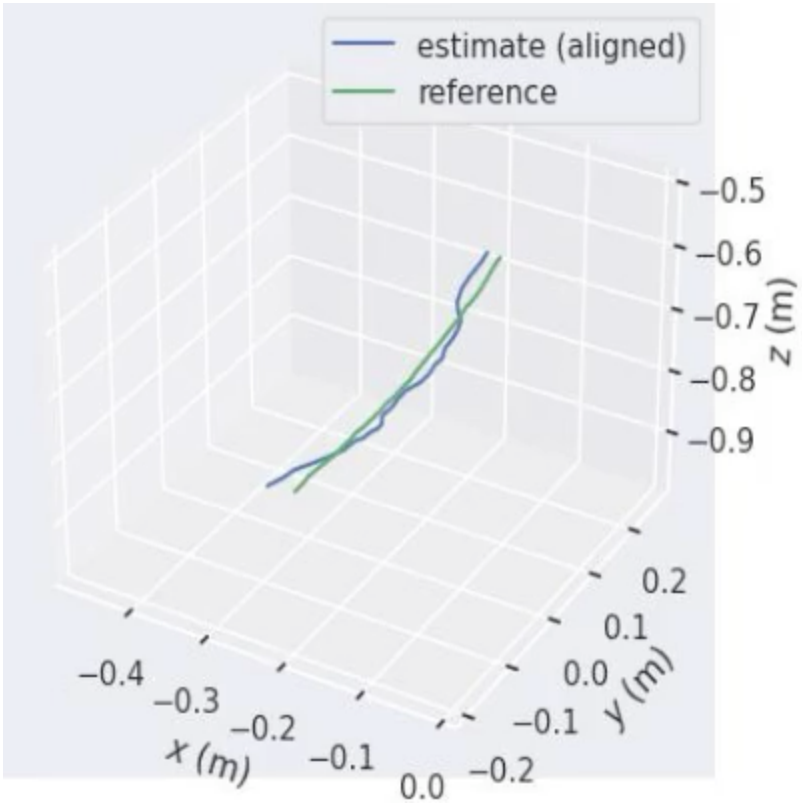

## MonoNeRF

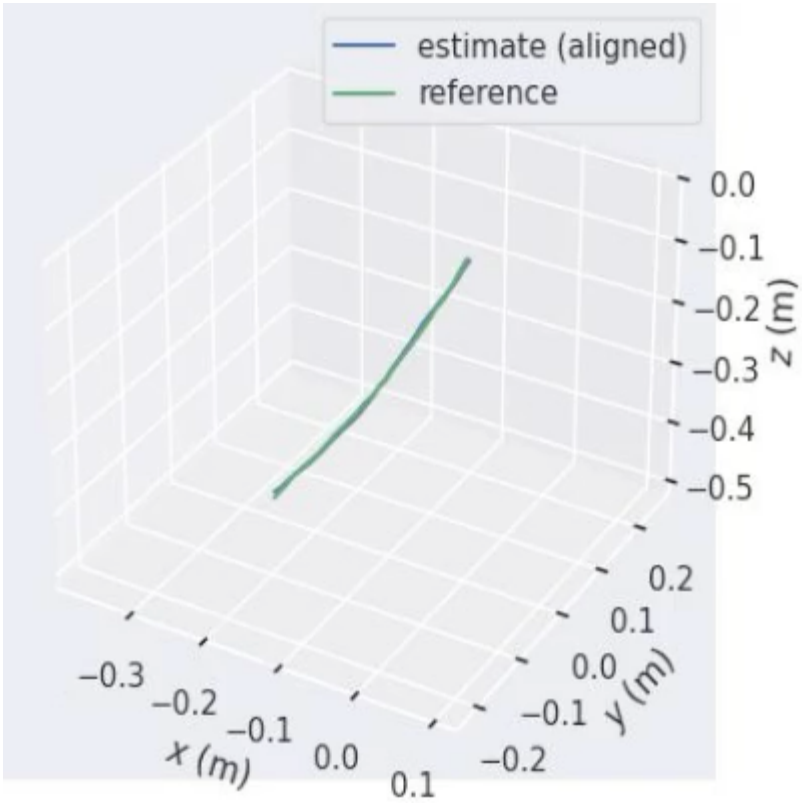



# Camera Pose Estimation

## Input Video



## VideoAE

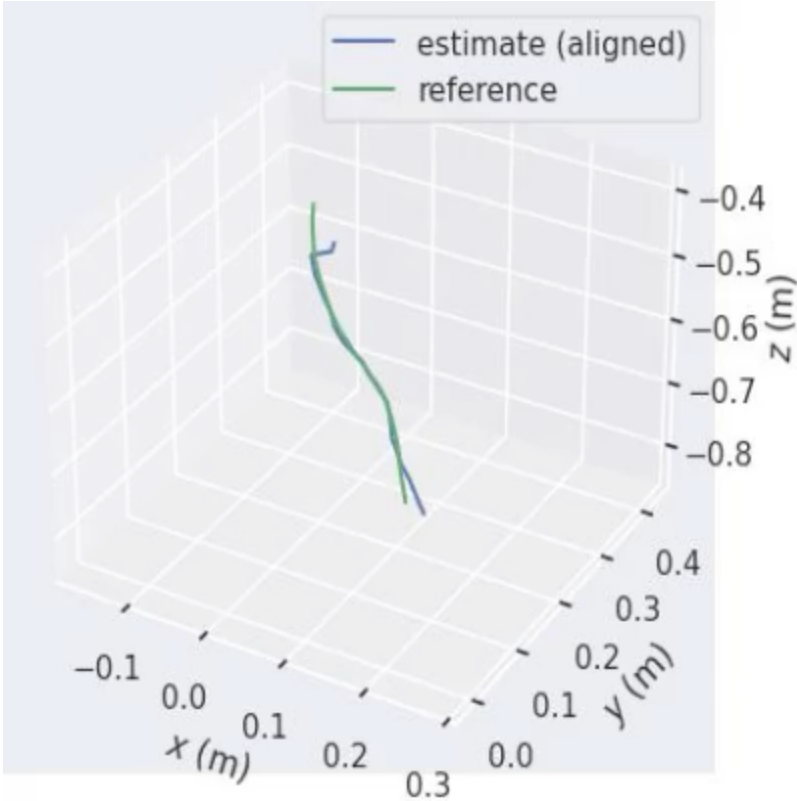

## MonoNeRF

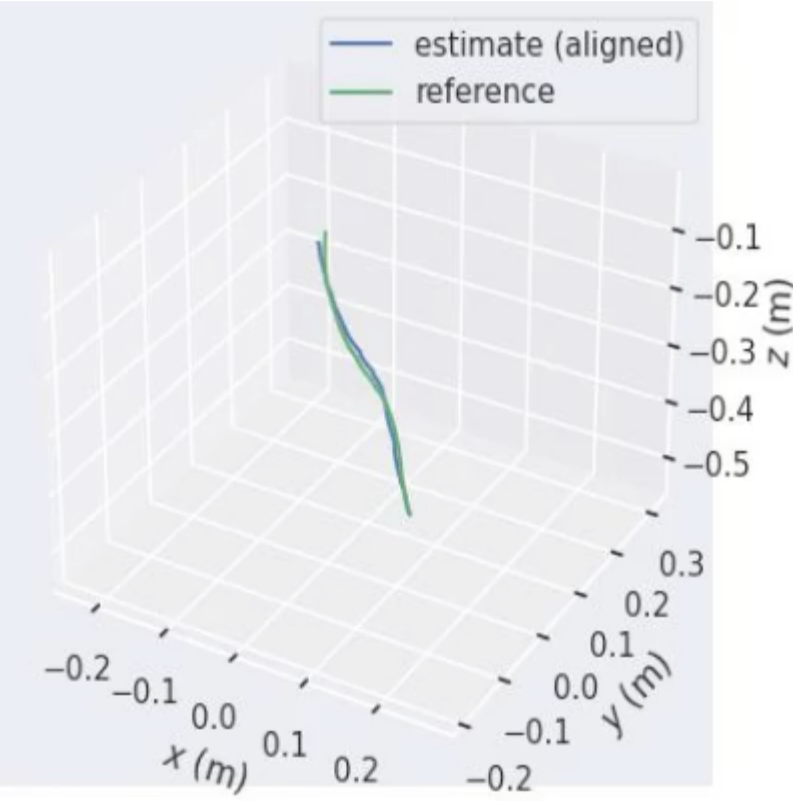

# Algorithm

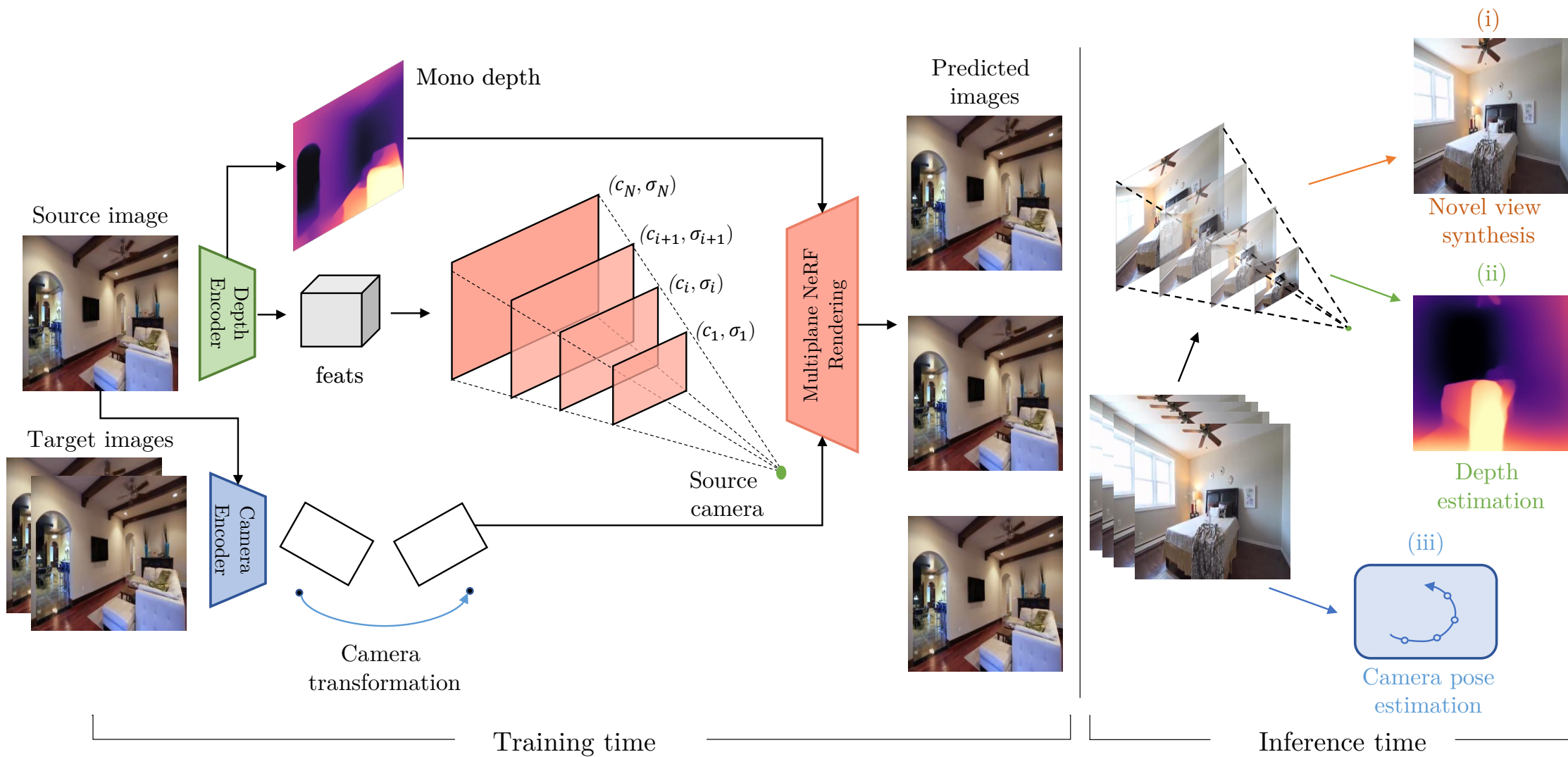

**Thanks!**